



# Veterinary Multiparameter Monitor Series

## Brio X3VET / Brio X5VET / Brio X7VET Operation Manual



**Brio X3VET**

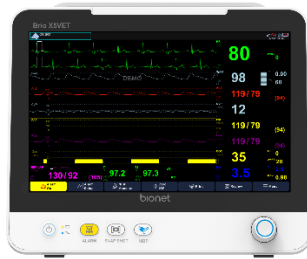

**Brio X5VET**

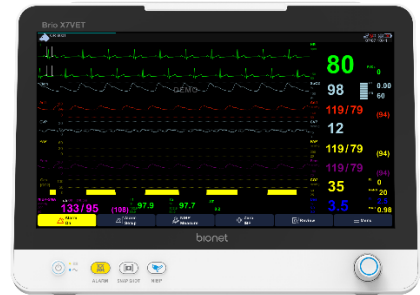

**Brio X7VET**

**Ver. 1.02**

2024. 04. 05



[www.ebionet.com](http://www.ebionet.com)

## REVISION HISTORY

Revision No.	Date	Contents	Page
1.00	2023.04.17	1. First Written	ALL
1.01	2023.11.06	1. Apply new logo and document format 2. Change model name 3. Chapter 1 - 4) Product Configuration > ECG 5 lead, delete disposable electrode 4. Chapter 1 - 4) Product Configuration > Delete ECG 3 lead 5. Chapter 1 - 4) Updating Product Feature Information 6. Chapter 12 - 4) Deletion of warning for human 7. Chapter 15 - 1) Deletion of N2O 8. Chapter 20 - 6) Change the default settings of ZeroRR, Temp, and RR for horses 9. Chapter 20 - 8) ST, RR lead default setting value change 10. Chapter 7 - 1), Chapter 7 - 8) description update Copyright Modification 11. Chapter 7-4) ECG measurement cable list update 12. Chapter 10-4) SpO2 sensor list update 13. Chapter 13-3) Delete Sidestream EtCO2 3471PED-00 Accessories 14. Chapter 14-3) Smith Medical accessories added 14. Chapter 15-2) Delete accessory DG-SENSOR 15. Chapter 16-4) Add accessories 16. Chapter 20 - 5) Dual gas specification update 17. Introduction - 2) Indicated for use added 18. Chapter 15) Hal, Enf deleted. MAC	

		<p>formular Update.</p> <p>19. Chapter 6-5) Update trend export picture and add description</p> <p>20. AVR, AVL, AVF notation changed to aVR, aVL, aVF</p> <p>20. Chapter 2-2) AC Filter menu added</p> <p>21. Chapter 20-6) Change SpO2-Rate, HR, EtCO2-zeroRR alarm default values</p> <p>22. Chapter 2-2) G.Calibration menu added</p> <p>23. Chapter 2-2), Chapter 18-5) Added caution for touch screen calibration</p> <p>24. Chapter 3-2) Added note regarding USB wifi dongle recognition</p> <p>25. Chapter 5-2) Alarm signal sound pressure level update</p> <p>26. Chapter 10-2) Added a warning about the duration of attachment of the spo2 sensor and added a warning about the use of electrosurgical devices.</p> <p>27. Chapter 14-2) Addition of warning phrase for use of electrosurgical device</p> <p>28. Chapter 2-2), Chapter 18-5) Added equipment time setting information</p> <p>29. Chapter 1-1) Add caution on using parts and accessories specified in the manual</p> <p>30. Chapter 3-2) Deleting TP-LINK T2U plus from a supported USB Wi-Fi Dongle</p> <p>31. Chapter 20-5) Change of HR range notation in ECG specifications</p> <p>32. Chapter 20-5) Pace pulse markers, tall T-wave rejection capability deleted from ECG specifications</p> <p>33. Chapter 11-5) Small Cuff Pressure Range Change</p>	
1.02	2024.04.05	<p>Contact &gt; Renewal of European sales contact information</p> <p>Chapter 11-2) Add 6 types of cuff</p>	5p

---

		Chapter 1-7) Bionet Engraving Delete	

## Warranty

- This product is manufactured through our strict quality control and inspection process. Compensation standards for product repair and exchange follow the "Regulations of Compensation for Consumer's Damage" announced by the Fair-Trade Commission.
- Any questions regarding the warranty should be directed to the local sales or service representative.
- If a malfunction occurs under normal use, our service representative will repair it free of charge during the warranty period.
- If a problem occurs with the equipment during the warranty period, please notify us of the model name, serial number, date of purchase, and malfunction details.

---

## Contact

If you have any questions or comments relating to our products or purchasing, please contact the telephone numbers or E-mail below. You can talk to our sales people. Bionet always welcomes your enquiries. Please contact us.

---

**Headquarters &  
International****Bionet Co., Ltd.:**

5F, 61 Digital-ro 31 gil, Guro-gu, SEOUL 08375,  
REPUBLIC OF KOREA

**Sales & Service**

Tel : +82-2-6292-6410 / Fax : +82-2-6499-7789

E-mail : [service@ebionet.com](mailto:service@ebionet.com)

Website: [www.ebionet.com](http://www.ebionet.com)

---

**U.S.A****Bionet America, Inc.**

2691 Dow Ave. Suite B, Tustin, CA 92780

**Sales & Service**

Toll Free : 1-877-924-6638 / Fax : 1-714-734-1761

**Representative**

E-mail : [support@bionetus.com](mailto:support@bionetus.com)

Website: [www.bionetus.com](http://www.bionetus.com)

---

**European****Bionet Europe GmbH :**

2Li Bessemerstr. 51, D-12103 Berlin, Germany

**Sales & Service**

Tel : +49-30-240-374-52

**Representative**

E-mail : [be@ebionet.com](mailto:be@ebionet.com)

Website: <https://bionet-europe.com/>

---

※ In the event of a malfunction or failure, contact Service Dept. Of Bionet Co., Ltd. along with the model name, serial number, date of purchase and explanation of failure.

## Paid Service

**A fee will be charged for all services except for breakdowns, so be sure to read this Operation manual below before putting in a request.**

<ul style="list-style-type: none"> <li>- Usage description and simple inspection without disassembly</li> <li>- In case of reinstallation due to poor installation by a distributor</li> </ul>	<p style="text-align: center;">Free the 1<sup>st</sup> time Charged starting the 2<sup>nd</sup> time</p>
<ul style="list-style-type: none"> <li>- Inadequate installation or loosening due to physical product movement, relocation, etc.</li> <li>- When re-installing after the first installation requested by the customer at the time of purchase</li> <li>- When reinstallation is required due to inexperienced installation by the customer</li> <li>- When a service is requested due to the input of foreign substances or improper cleaning</li> </ul>	<p style="text-align: center;">Charged starting the 1<sup>st</sup> time</p>

### **1. Equipment cleaning, adjustment, and usage description are not product breakdowns.**

(If repair is not possible, separate standards will apply)

### **2. Breakdowns caused by consumer negligence**

Breakdowns and damage due to careless handling by the customer or incorrect repair are caused by:

- Using incompatible electric capacity.
- Mishaps such as dropping the product.
- Using the third party replacements or options not specified by our company.
- Non-Bionet technicians or agency technicians in the process of repair.

### **3. Other cases**

- Breakdowns by natural disasters (fire, salt damage, flood damage, earthquake, etc.)
- When a consumable part has reached the end of its life (accessory)

# Table of Contents

Warranty .....	5
Contact .....	6
Paid Service .....	7
Introduction.....	14
1) Intended Use (Indications for Use) .....	14
2) Contraindications .....	14
3) Functional Safety .....	15
4) Warnings, Cautions and Notes .....	15
5) Definition of Groups .....	16
6) Electromagnetic Compatibility .....	18
7) Electronic Device Connection Precautions.....	19
<b>PART 1. Basic .....</b>	<b>20</b>
1) Electric Safety Precautions.....	20
2) Equipment Connection .....	22
3) Biocompatibility .....	22
4) Product Configuration .....	23
5) Basic Unit.....	26
6) Device Markings.....	36
7) Power .....	37
8) Getting Started.....	42
<b>PART 2. Setup .....</b>	<b>46</b>
1) Overview.....	46
2) Main Menu.....	46
3) Parameter Calibration .....	52
4) Maker Service .....	53
<b>PART 3. Network.....</b>	<b>55</b>
1) Overview.....	55
2) Network Connection .....	56
3) IT Network Connection.....	58
4) LAN Network .....	59
5) VLAN Network.....	59

---

6) Inappropriate Network .....	60
7) B2B View .....	61
8) B2B Settings.....	63
<b>PART 4. Admission and Discharge.....</b>	<b>65</b>
1) Overview.....	65
2) Admitting a Patient.....	65
3) Editing Patient Information .....	66
4) Discharging a Patient.....	67
5) Patient Management Menu .....	67
6) Registering Patient ID Using Barcode .....	68
<b>PART 5. Alarm.....</b>	<b>69</b>
1) Overview.....	69
2) Alarm Priority .....	69
3) Alarm Type.....	70
4) Alarm Status .....	73
5) Setting an Alarm.....	75
6) Alarm Events.....	76
<b>PART 6. Trend.....</b>	<b>79</b>
1) Overview.....	79
2) Tabular Trend .....	79
3) Graphic Trend.....	81
4) Setting Trend.....	84
5) Exporting a Trend file.....	84
6) Popup Trend.....	86
7) Troubleshooting.....	86
<b>PART 7. ECG .....</b>	<b>88</b>
1) Overview.....	88
2) ECG Precautions .....	88
3) Preparing the Patient.....	91
4) Connector and Measuring Cable .....	92
5) Attaching Electrodes .....	95
6) ECG Lead.....	97
7) ECG Signal Processing and Display.....	98

8)	ST Signal Processing and Display.....	99
9)	Alarm and Its Status .....	99
10)	Display .....	99
11)	Setting ECG .....	100
12)	Full Disclosure Review .....	101
13)	Troubleshooting.....	103
<b>PART 8. Monitoring Arrhythmia.....</b>		<b>105</b>
1)	Overview.....	105
2)	Arrhythmia Template .....	105
3)	Setting Arrhythmia.....	106
<b>PART 9. RESPIRATION .....</b>		<b>108</b>
1)	Overview.....	108
2)	RESP Precautions .....	108
3)	Preparing the Patient.....	108
4)	Display .....	109
5)	Respiration Setting Menu .....	110
<b>PART 10. SpO2 .....</b>		<b>111</b>
1)	Overview.....	111
2)	Precautions.....	111
3)	Preparing the Patient.....	112
4)	Connector and Measurement Cable .....	113
5)	Display .....	116
6)	Signal and Data Validity.....	117
7)	SpO2 Setting Menu .....	118
8)	Troubleshooting.....	119
<b>PART 11. NIBP .....</b>		<b>120</b>
1)	Overview.....	120
2)	Connector and Cuff.....	121
3)	Position of cuff.....	123
4)	Display .....	125
5)	NIBP Setting Menu.....	126
6)	Measurement Restrictions .....	128
7)	Selecting and Placing the Cuff.....	128

---

8) Troubleshooting.....	130
9) Calibration.....	131
<b>PART 12. Temperature.....</b>	<b>132</b>
1) Overview.....	132
2) Preparing the Patient.....	132
3) Connector and measurement cable .....	132
4) Display .....	134
5) Temp Setting Menu .....	135
6) Troubleshooting.....	135
<b>PART 13. EtCO2 .....</b>	<b>136</b>
1) Overview.....	136
2) EtCO2 Caution .....	136
3) Connector and Measurement Accessory.....	138
4) CO2 Measurement Restrictions.....	141
5) Display .....	142
6) How to Sample.....	142
7) Zero Calibration .....	147
8) EtCO2 Setting Menu.....	148
9) Troubleshooting.....	150
<b>PART 14. Invasive Blood Pressure (IBP).....</b>	<b>151</b>
1) Overview.....	151
2) Precautions.....	151
3) Connector and Measurement Kit.....	152
4) Display .....	154
5) Procedures .....	155
6) List & Description of IBP Measurement Parameter Label.....	155
7) IBP Setting Menu.....	156
8) Troubleshooting.....	158
<b>PART 15. Anesthetic Gas (AG) – Dual Gas module .....</b>	<b>159</b>
1) Overview.....	159
2) Connectors and Accessories .....	159
3) MAC value.....	162
4) Display function .....	162

---

5) Dual gas setup .....	163
<b>PART 16. Anesthetic Gas (AG) – ParaMount module .....</b>	<b>165</b>
1) Overview.....	165
2) AG Measurement Restriction .....	167
3) AG Display.....	167
4) Connecting a Patient to AG Device .....	168
5) Preparing AG Monitoring.....	170
6) MAC value.....	171
7) AG Setting Menu .....	173
8) Making Changes in Anesthetic .....	174
9) Performing AG Leakage Test.....	174
10) AG Module Calibration .....	175
11) Troubleshooting.....	175
<b>PART 17. Printer .....</b>	<b>176</b>
1) Overview.....	176
2) Printer Setting Menu .....	176
3) Storing the Thermal Paper.....	177
4) Changing the Paper.....	178
5) Troubleshooting.....	178
<b>PART 18. Maintenance and Troubleshooting .....</b>	<b>180</b>
1) Maintenance Safety Information .....	180
2) Equipment Inspection .....	180
3) Cable Inspection.....	181
4) Maintenance Tasks and Test Schedule.....	182
5) Troubleshooting.....	182
<b>PART 19. Cleaning and Care.....</b>	<b>184</b>
1) Overview.....	184
2) Monitor and Accessories.....	184
<b>PART 20. Technical Specifications.....</b>	<b>189</b>
1) Overview.....	189
2) EMC Compatibility (EMC).....	189
3) Manufacturer’s Declaration - Electromagnetic Emission .....	190
4) Manufacturer’s Declaration - Electromagnetic Immunity.....	192

---

5) System Specifications .....	197
6) Default Parameter Alarm Settings .....	213
7) Default Technical Alarm Settings .....	215
8) Default Display Settings.....	219
<b>PART 21. Abbreviations and Symbols.....</b>	<b>221</b>
1) Abbreviations.....	221
2) Symbols .....	224
<b>PRODUCT WARRANTY.....</b>	<b>226</b>

---

# Introduction

\* The terms of veterinary multiparameter monitoring device or veterinary multiparameter monitor used in this manual refer to Brio X3VET / Brio X5VET / Brio X7VET .

## 1) Intended Use

The veterinary multiparameter monitors are intended for monitoring, displaying, reviewing, storing, notifying, and transferring of multiple physiological signs of animals, such as ECG (3-Lead, 5-Lead selectable), arrhythmia detection, ST-segment analysis, Heart Rate (HR), Respiration rate (Resp), Temperature (Temp), Pulse Oxygen Saturation (SpO2), Pulse Rate (PR), Non-invasive Blood Pressure (NIBP), End-tidal Carbon Dioxide Concentration (EtCO2), Invasive Blood Pressure (IBP) and Anesthetic Gas (AG).

## 2) Indications for Use

The veterinary multiparameter monitors are indicated for use by clinicians in hospital environments and are for prescription use only.

The veterinary multiparameter monitors are not indicated for helicopter transport, hospital ambulance, or home use.

They should only be used by persons who have received adequate training in their use.

The patient monitors are continuously display multiple physiological signs. All the parameters could be monitored on single dogs, cats, horses and other small animals.

## 3) Contraindications

The following bullet lists describe when and where the veterinary multiparameter monitors are not Intended for Use:

- As therapeutic device
- Domestic use
- In transport situations within hospital environments
- During MRI
- As apnea monitors

- ECG measurements are not intended to be used for diagnosis of rhythm and morphology of cardiac complexes.

## 4) Functional Safety

The essential function of the veterinary multiparameter monitors is to provide the healthcare practitioner with meaningful parameter values.

An alarm occurs if the parameter values are out of the specified range or when they are not provided properly.

Bionet has assessed the risks associated with the use of the veterinary multiparameter monitors in consideration of the main functions and has mitigated the risks threatening their product life, provided that they are used in compliance with service recommendations and regular maintenance.

## 5) Warnings, Cautions and Notes

Read the "Warnings, Cautions and Notes" thoroughly to ensure safety and to prevent product damage before using the veterinary multiparameter monitors. Be sure to follow the "Warnings, Cautions and Note" indicated below, as these are important messages related to safety.

Specifications or functions described in this manual are subject to change without notice for product improvement.

<b>Warning</b>	<b>[Warning] Failure to follow this message may cause severe injuries, casualty or physical damage to patients.</b>
<b>Caution</b>	<b>[Caution] Failure to follow this message may cause in non-life-threatening injury or damage to the equipment.</b>
<b>Note</b>	<b>[Note] indicates some important information and tips, which are not dangerous, about installation, operations and maintenance.</b>

## 6) Definition of Groups

Bionet defines user groups of the veterinary multiparameter monitors as Users, Service representative, and Experts.

All defined groups should read this operation manual very carefully before starting to use the veterinary multiparameter monitors and should be trained in their use, installation, reprocessing, maintenance, and repair.

The veterinary multiparameter monitors can be used, installed, reprocessed, maintained, and repaired by the defined groups only.

### User

Users shall use the veterinary multiparameter monitors for their intended use.

### Service representative

Service representative are responsible for the maintenance of the veterinary multiparameter monitors.







They shall be trained in the installation, reprocessing, and maintenance of them.

### Expert

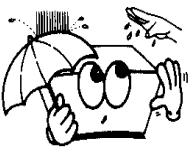
The experts shall have enough knowledge and experience to repair or conduct the complicated maintenance tasks on the veterinary multiparameter monitors.

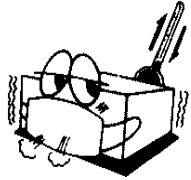
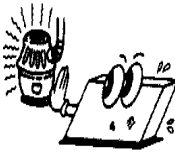
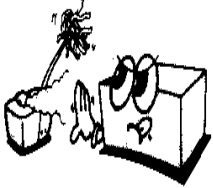
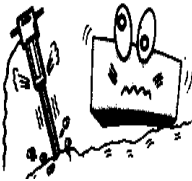
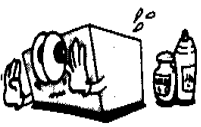
## General Precautions on Environment

DO NOT store or operate the equipment in the places listed below.

	<p>A place exposed to moisture</p> <p>(DO NOT touch the equipment with wet hands.)</p>		<p>A place under direct sunlight</p>
	<p>A place in areas with highly fluctuating temperatures.</p>		<p>A place in the vicinity of Electric heater</p>
	<p>A place with excessive humidity rise or poor ventilation</p>		<p>A place with sources that cause excessive shock or vibration</p>
	<p>A place exposed to chemicals or at risk of gas leakage</p>		<p>Avoid the invasion of small objects/ particles such as dust, and especially avoid metallic material.</p>
	<p>Do not disjoint or disassemble the equipment. (Bionet is not liable for broken products caused by attempted disassembly).</p>		<p>DO NOT connect power until the product is completely installed. It may cause damage to the product.</p>

## 7) Electromagnetic Compatibility

The veterinary multiparameter monitors have been designed and tested for compliance with current regulatory standards as to their capacity to limit electromagnetic emission (EMI), and as to their ability to block the effects of EMI from external sources.

They comply with the following standards pertaining to EMI emissions and susceptibility: EN60601-1-2.

To reduce possible hazardous situations caused by electromagnetic interference, we recommend the following:

- Use only accessories provided by Bionet.
- Ensure that other products used in areas where veterinary multiparameter monitors and life support are used comply to accepted emissions standards (CISPR 11, Class A).
- Try to maximize the distance between electro-medical devices. High-power equipment related to electrical simulators, electrosurgical instruments, and radiators (X-ray machines), as well as evoked potential devices may cause monitor interference.
- Strictly limit exposure and access to portable radio frequency sources (e.g., cellular phones and radio transmitters). Be aware that portable phones may periodically transmit even when in standby mode.
- Maintain good cable management. Do not route cables over electrical equipment. Do not intertwine cables.
- Ensure all electrical maintenance is performed by qualified personnel.

**Caution****Infectious devices and parts must be sanitized and cleaned before disposal.**

## 8) Electronic Device Connection Precautions

**SHOCK HAZARD** — Improper use of this equipment may cause electric shock. Strictly observe the following guidelines. Failure to do so may endanger the lives of the patient, user, and bystanders.

To disconnect the equipment from the power line, first remove the power plug from the wall outlet before disconnecting the cables from the equipment; Otherwise, there is a risk that metal parts inadvertently inserted into the power cord socket comes into contact with line voltage.

Additional devices connected to medical electrical equipment shall comply with the respective IEC or ISO standards (e.g., IEC 60950 for data processing equipment).

Additionally, all configurations must comply with the requirements for medical electrical system. (See IEC 60601-2 or Clause 16 of IEC 60601-1 edition 3.2.)

Anyone who connects additional devices to medical electrical equipment is in the position of configuring medical system, and is responsible for complying with the requirements of medical electrical system.

Keep in mind that local legislation takes precedence over the above-mentioned requirements. If in doubt, consult your local representative or the technical service department.

**POWER REQUIREMENTS**— Before connecting the equipment to the power line, check that the voltage and frequency ratings of the power line are the same as those indicated on the equipment's label. If this is not the case, do not connect the equipment to the power line until you adjust it to match the power source.

In the USA, if the installation of this equipment uses 240V instead of 120V, the source must be center tapped, 240V single-phase circuit.

This equipment is suitable for connection to public mains as defined in CISPR 11.

Equipment connected to the ECG system and in the patient, environment must be powered from a medically isolated power source or must be a medically isolated device. The equipment powered from a non-isolated source can result in chassis leakage currents exceeding safe levels. Chassis leakage current created by an accessory or device connected to a non-isolated outlet may add to the chassis leakage current of the ECG system.

## PART 1. Basic

### 1) Electric Safety Precautions

<b>Warning</b>	<p>The veterinary multiparameter monitor must be connected to an appropriate power source before use.</p> <p>Before using the veterinary multiparameter monitor, check whether its power supply line is appropriate (AC100 - 240V).</p>
<b>Caution</b>	<p>Please check the following before using the veterinary multiparameter monitor:</p> <ul style="list-style-type: none"> <li>● Ensure that the power source is supplied from Bionet.</li> <li>● Use only parts and accessories specified in this manual.</li> <li>● Ensure that the entire connection of the veterinary multiparameter monitor cables is properly and firmly fixed.</li> <li>● Each monitor requires an independent circuit and a stable ground. When using the same power supply with other electrical devices, inaccurate measurements may occur.</li> <li>● The veterinary multiparameter monitor should be distanced from generators, X-ray equipment, broadcasting equipment, or transmitting wires to prevent electrical noises from being generated during the operation, producing inaccurate measurements. For Brio veterinary multiparameter monitor series, both independent circuit and stable grounding are required. Sharing the same power source with other electronics can also produce inaccurate outputs.</li> </ul>
<b>Warning</b>	<p>Avoid physical contact with the patient during defibrillation, as it may cause serious injury or death. When using the defibrillator, follow standard safety precautions and only use the supplied cable.</p>

<b>Warning</b>	In case the medical equipment does not operate normally, or if it has been damaged, do not use it on any patient; Contact the medical equipment technician in your hospital or the equipment supplier.
<b>Warning</b>	<ul style="list-style-type: none"><li>● To reduce the hazard of burns during high-frequency surgical procedures, ensure that the cables and transducers of the veterinary multiparameter monitor never come into contact with the high-frequency surgical units.</li><li>● The neutral electrode of the electro-surgery unit (ESU) must properly contact the patient, to prevent accidental burning of the patient.</li></ul>
<b>Note</b>	<p>The veterinary multiparameter monitor is classified as follows:</p> <ul style="list-style-type: none"><li>● It is classified as Class I, BF &amp; CF concerning electric shock.</li><li>● It is classified as IPX2 for waterproofing, and according to KS C IEC 60529, it does not have a harmful effect on vertically falling water drops when inclined within 15 degrees.</li><li>● Noise level is A class regarding IEC/EN 60601-1 and the subject of Noise is A level concerning IEC/EN60601-1-2.</li></ul>
<b>Note</b>	<p><b>Waterproof Precautions</b></p> <ul style="list-style-type: none"><li>● It is not proper to operate the veterinary multiparameter monitor around combustible anesthetics or dissolvents.</li><li>● If you spill liquid on the veterinary multiparameter monitor, battery, or accessories, or if they are accidentally soaked in liquid, contact your service representative or the equipment supply division. Do not operate them before they have been tested and approved for further use.</li></ul>

## 2) Equipment Connection

<b>Caution</b>	<ul style="list-style-type: none"><li>• Doctors and patients in hospitals are exposed to the risk of uncontrollable currents. These currents are caused by a potential difference between the veterinary multiparameter monitor and conductive objects, which may come into the monitor. To solve this problem, make sure that the auxiliary equipment connected to the veterinary multiparameter monitor satisfies EN60601-1..</li><li>• Unsecured equipment may fall on the patient. Fix the equipment securely during installation.</li></ul>
----------------	--

<b>Note</b>	For measurements in or near the heart, it is recommended to connect the veterinary multiparameter monitor to a potential equalization system. Use a potential equalization cable to connect to the pin marked with the equipotential symbol.
-------------	--

<b>Note</b>	The veterinary multiparameter monitor uses a main plug as isolation means to the mains power. Do not place it in a place difficult to access the mains plug.
-------------	--

## 3) Biocompatibility

When used as intended, the parts of the veterinary multiparameter monitor described in this operator manual, including accessories that come in contact with the patient during the intended use, fulfill the biocompatibility requirements of the applicable standards. If you have questions about this matter, please contact Bionet or its representatives.

---

## 4) Product Configuration

### Basic components

1. Main body of Brio X3VET / X5VET / X7VET monitor -----1 EA
2. 3-Lead ECG extension cable -----1 EA
3. 3-Lead ECG patient cable -----1 EA
4. NIBP extension tube -----1 EA
5. Veterinary NIBP Cuff (#1~#5)-----1 EA
6. SpO2 extension cable -----1 EA
7. Reusable animal SpO2 probe-----1 EA
8. Operation manual -----1 EA
9. Power Cord -----1 EA

### Optional modules

1. Paramount module for monitoring AG (Brio X5VET, Brio X7VET only)
2. Dual gas module for monitoring AG
3. Printer module

### Optional components

1. Reusable temperature probe
2. Sidestream EtCO2 module (Respironics)
3. Mainstream EtCO2 module (Respironics)
4. Sidestream EtCO2 sample lines
5. Mainstream EtCO2 airway adapters
6. 5-Lead ECG extension cable
7. 5-Lead ECG patient cable
8. IBP extension cable
9. IBP transducer set (Disposable/Reusable)
10. Anesthetic Gas watertrap
11. Anesthetic gas sample line

<b>Warning</b>	To avoid electrical shock, do not open the cover. Disassembling the veterinary multiparameter monitor should be done only by service representative authorized by Bionet.
----------------	---

<b>Warning</b>	<ul style="list-style-type: none"><li>• Use only installation accessories specified by Bionet.</li><li>• Connect only approved devices to the veterinary multiparameter monitor.</li></ul> <p>Devices connected to the veterinary multiparameter monitor must meet the requirements of the applicable IEC standards (e.g. IEC 60950 safety standards for information technology equipment and IEC 60601-1 safety standards for medical electrical equipment). The system configuration must meet the requirements of the IEC 60601-1 medical electrical systems standard.</p> <p>Any personnel who connect devices to the signal input/output port of the veterinary multiparameter monitor are responsible for providing evidence that the safety certification of the connected devices has been approved in accordance to the IEC 60601-1. If you have any questions, please contact Bionet.</p> <ul style="list-style-type: none"><li>• If it is not evident from the device specifications whether a particular combination with other devices is hazardous, for example, due to summation of leakage currents, please consult the manufacturer or an expert in the field. A determination must be made that the proposed combination does not negatively affect the devices themselves or the patient's safety.</li></ul>
----------------	---

<b>Note</b>	All Bionet hardware drawings and screen shots in this operation manual are for illustrative purposes only. The actual product may differ slightly from drawings and screenshots used herein.
-------------	--

## Product Feature Information

\*basics: ●

\*option: ○

Function	Brio X3VET	Brio X5VET	Brio X7VET
Display	8"	12.1"	15.6"
ECG 3-Lead	●	●	●
ECG 5-Lead	○	○	○
Respiration	●	●	●
Bionet SpO2	●	●	●
Suntech NIBP	●	●	●
2CH IBP	●		
4CH IBP		●	●
EtCO2	○	○	○
2 Temp	●	●	●
Paramount		○	○
AG		○	○
Dual gas	○	○	○
Battery(3250mAh)	●	●	●
Battery(6500mAh)	○	○	○
B2B	●	●	●
HL7	●	●	●
Full disclosure	●	●	●
Wi-Fi	●	●	●
Printer	○	○	○

## 5) Basic Unit

Front view

Brio X3VET

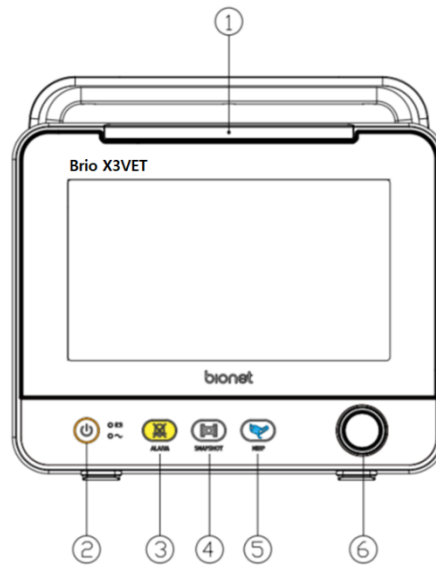

Brio X5VET

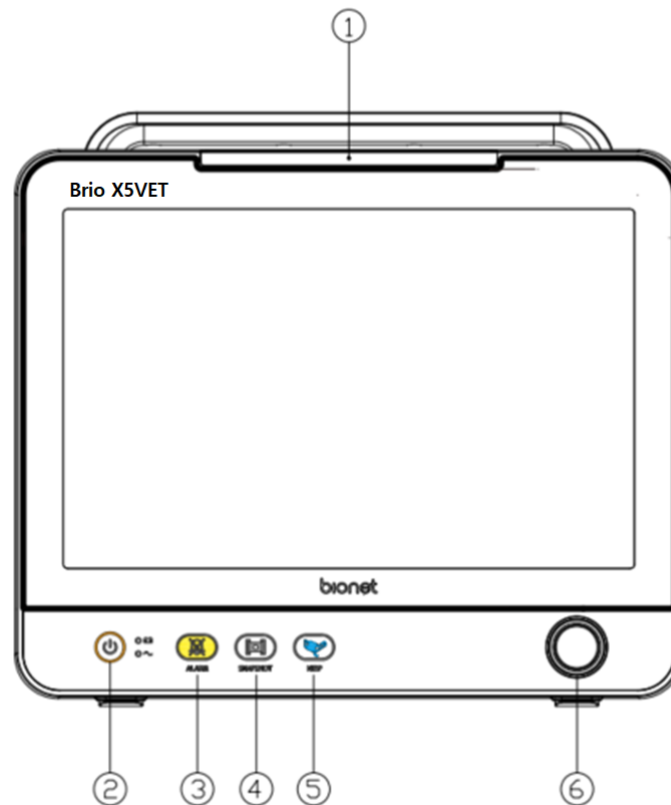

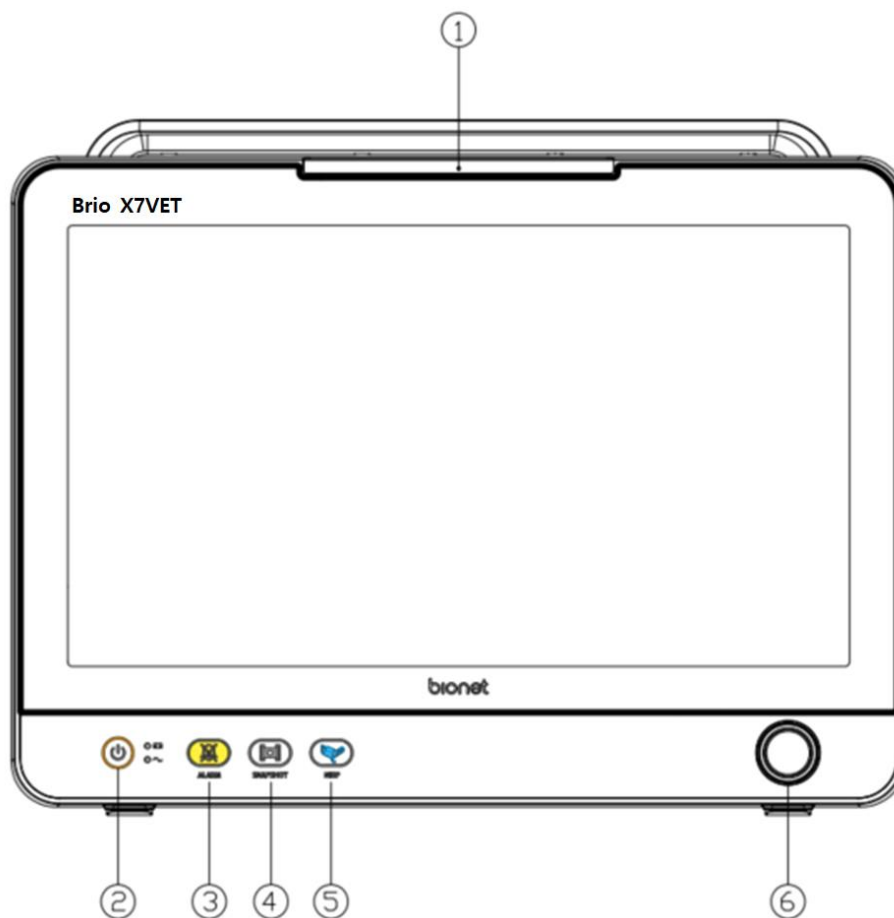
**Brio X7VET**

- ① Alarm lamp
- ② Power ON/OFF Key
- ③ Alarm control key
- ④ Screen shot key
- ⑤ Blood pressure measurement key
- ⑥ Rotary knob

**Left side view**

**Brio X3VET**

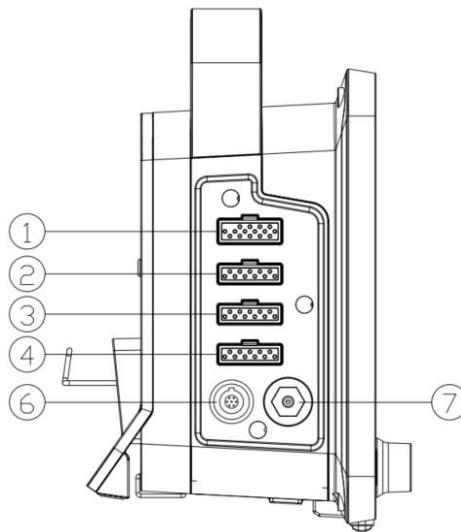

**Brio X5VET**

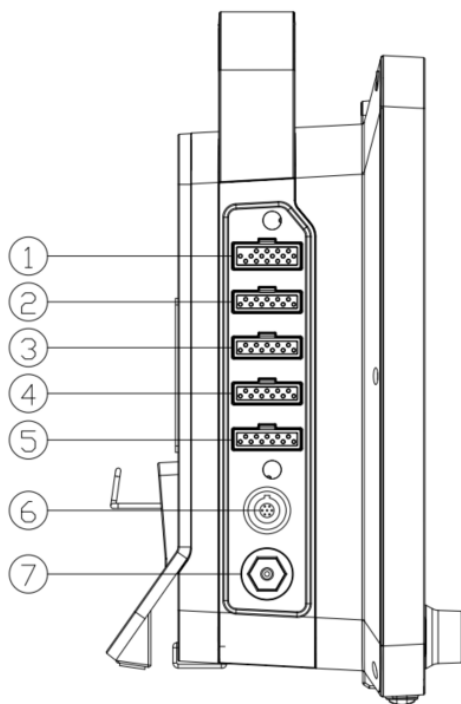

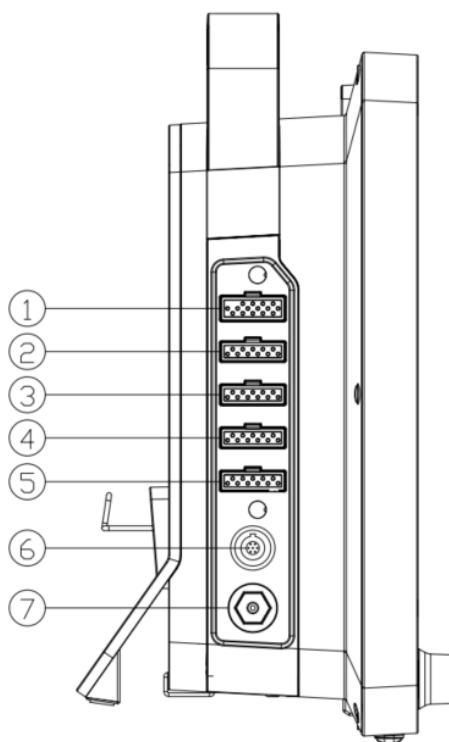
**Brio X7VET**

- ① ECG connector
- ② SpO2 connector
- ③ Temperature connector
- ④ IBP connector
- ⑤ IBP connector2
- ⑥ EtCO2 / Dual Gas Module Connector
- ⑦ Blood pressure tube connector

Right side view

Brio X3VET

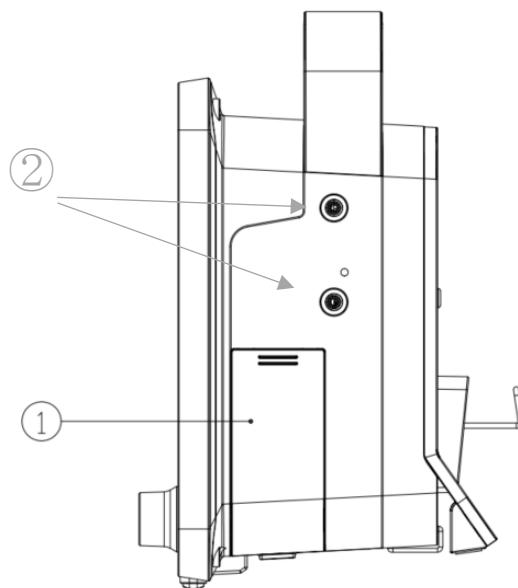

Brio X5VET

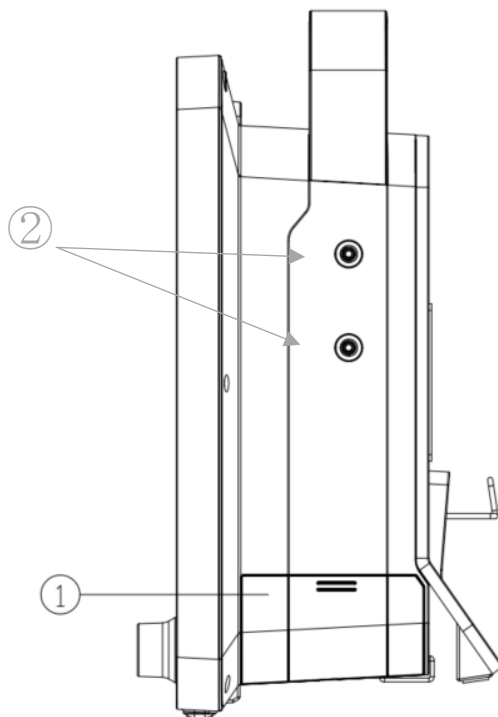

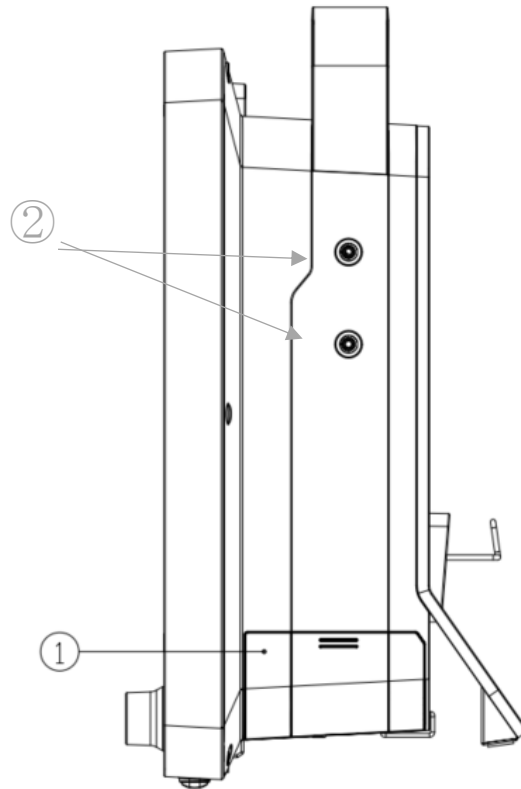
**Brio X7VET**

- ① Battery cover
- ② Printer bracket

Back side view

Brio X3VET

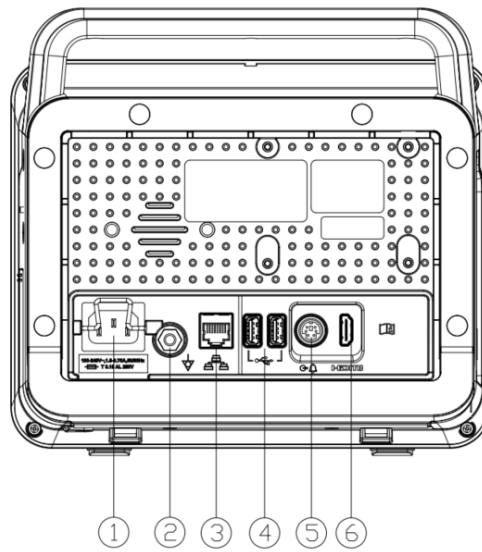

Brio X5VET

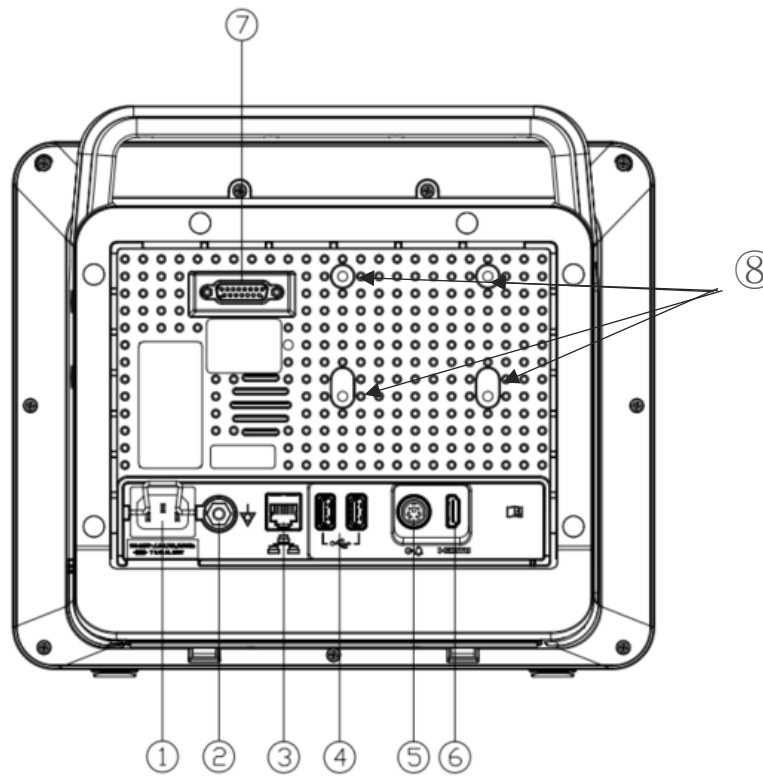

## Brio X7VET

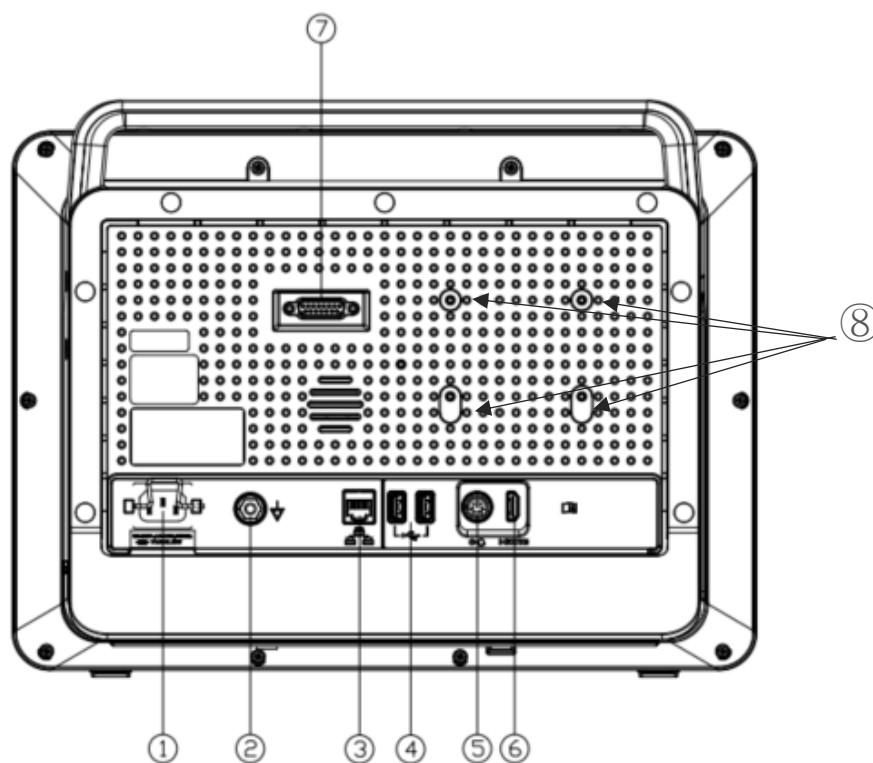

- ① AC input connector
- ② Equipotential Grounding Terminal
- ③ LAN port
- ④ USB port (USB 2.0 5Vdc / Max. 500mA)
- ⑤ Printer connector
- ⑥ HDMI output port
- ⑦ Paramount module connector
- ⑧ Paramount / Dual Gas Module Bracket

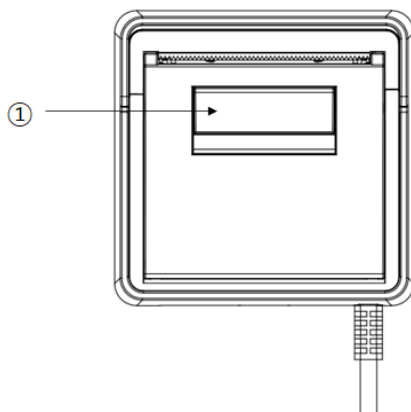
**Printer module (option)**

- ① Printer door lever

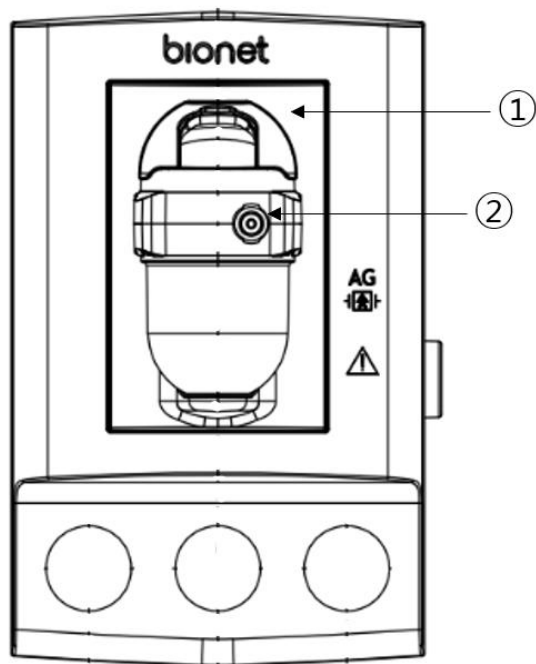
**Paramount module (option)**



















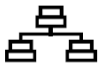

- ① AG (Anesthetic Gas) watertrap
- ② Gas sample line connector





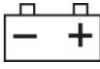

<b>Warning</b>	<p><b>USB compatible</b></p> <ul style="list-style-type: none"><li>● The veterinary multiparameter monitor is compatible with external USB memory drives up to 64GB.</li><li>● We recommend the products of the brands listed in the manual (Sandisk, PNY, Transcend, Samsung).</li><li>● When using a product with high power consumption, such as an external hard drive, be sure to use the adapter dedicated to it for suitable power supply. (You can't use it with the veterinary multiparameter monitor's power supply alone.)</li><li>● It is recommended to save the data of the connected devices before connecting any additional devices. Bionet recommends backing up data on an existing storage device before connecting a new storage device.</li><li>● Some high power USB devices may not be supported.</li></ul> <p><b>Paramount Connection</b></p> <ul style="list-style-type: none"><li>● Connect the veterinary multiparameter monitor to a Paramount module with the power turned off.</li></ul>
----------------	---

<b>Note</b>	<p>The HDMI output of Brio X3VET , Brio X5VET , and Brio X7VET is 1024x600 @60Hz, 1280x800 @60Hz. and 1366x768 @60Hz, respectively.</p> <p>Depending on the specifications of the veterinary multiparameter monitor, the screen may not display the output, so please check beforehand.</p>
-------------	---

<b>Note</b>	<p>When using the veterinary multiparameter monitor together with other devices, connect their equipotential grounding terminals together to eliminate the potential difference between them.</p>
-------------	---

## 6) Device Markings

	Caution: Consult accompanying documents		Type BF applied part
	Type CF applied part		ECG
	IP (Ingress Protection)		NIBP
	Temperature	SpO2	SpO2
	EtCO2		Grounding terminal
IBP	IBP		LAN port
	Anesthetic Gas(AG)	 SNAPSHOT	Snapshot
	Printer connector		USB port
<b>HDMI</b>	HDMI external port		Date of manufacture
	Alarm Key		WEEE (Waste Electrical and Electronic Equipment)
	NIBP Key		Battery charge indicator
	Power ON /OFF Key		Safety Sign: It indicates that you should read the user manual. Read the user manual before starting work or operating the equipment.
	AC Power		Medical device

	Consult instructions for use. This symbol advises the reader to consult the operating instructions for information needed for the proper use of the device.		Fragile
	This way up		Keep dry
	Use no hooks		Manufacturer
	Recycle		

## 7) Power

The veterinary multiparameter monitor uses AC power (100 -240VAC, 1.5~0.75A, 50/60Hz). In the event of a power outage or cable shortage, the monitor automatically switches to battery power to continue veterinary multiparameter monitoring without data loss. The built-in battery is intended for back-up use only during a power-outage.

When the power cable is connected to the back of the monitor, the AC input LED on the front lights up in green. When you press the power key, the monitor is powered on and ready to use.

<b>Warning</b>	<b>The veterinary multiparameter monitor must be connected to a protective earth grounded power supply.</b>
<b>Caution</b>	<b>Do not position the veterinary multiparameter monitor in a space that creates difficulty in unplugging its power supply cord.</b> <b>The veterinary multiparameter monitor can only be used with AC power (100 ~ 240VAC, 1.5 ~ 0.75A, 50/60Hz), and no other power source should be used.</b> <b>Do not connect AC power with wet hands.</b>

## Battery Power

The veterinary multiparameter monitor uses battery power when there is a power-outage, or during portable use scenarios.

When the AC power supply is cut off, the monitor immediately switches to battery power and continues to operate.







The battery is attached to the side of the monitor.

### Caution

**For a monitor without batteries, sudden interruption of AC power, such as a power outage, may result in loss of stored data or data corruption.**

## Operation

1. The battery is automatically charged when connected to AC power. The battery charge indicator LED on the front lights up in orange while the battery is being charged and turns green when charging is complete. While being charged, the battery icon is shown as charging in the upper right corner of the screen.
2. AC input LED and charging LED do not light up while the monitor is working on battery.
3. The charging status of the battery is displayed with a 5 step-diagram.

Battery Status Display		
Display	Charging Status	Remarks
	Charging	
	Fully charged.	
	80% of battery remaining	
	60% of battery remaining	If possible, connect the monitor to the AC adapter.
	40% of battery remaining	Immediately connect the monitor to the AC adapter.
	Battery is very low. (Power will turn off soon.)	Immediately connect the monitor to the AC adapter.
	No battery	Connect the battery.

<b>Caution</b>	<p>The battery status display is accurate only when the battery is functioning normally.</p> <p>Do not disassemble, modify, or heat the battery.</p> <p>Do not subject the battery to shock.</p> <p>Do not use if the battery shows signs of leakage, deformation, discoloration, or other abnormalities.</p> <p>The veterinary multiparameter monitor should only use batteries provided by Bionet</p>
<b>Note</b>	<p>When external power is not supplied, it takes about 2 minutes for the battery status display to reflect the actual remaining battery capacity.</p>

### Battery information

- Battery specification: Li-ion , 10.8V  
3BL3CABIO (3250mAh) (Default)  
6BL6CABIO (6500mAh) (Option)
- Battery charging time:  
3BL3CABIO: More than 3 hours  
6BL6CABIO: More than 5 hours
- Continuous battery usage time when fully charged:

#### **Brio X3VET**

- 3BL3CABIO: about 3 hours
- 6BL6CABIO: about 5 hours

#### **Brio X5VET**

- 3BL3CABIO: about 2 hours
- 6BL6CABIO: about 4 hours

#### **Brio X7VET**

- 3BL3CABIO: about 2 hours
- 6BL6CABIO: about 4 hours

\* (NIBP measured every 15 minutes with SpO2 and ECG, LCD brightness 80%)

<b>Warning</b>	<ul style="list-style-type: none"><li>● Capacity or operating time of old or defective batteries is significantly compromised.</li><li>● Bionet recommends replacing the lithium-Ion battery after 24 months of use.</li><li>● Remove the battery if the veterinary multiparameter monitor is not likely to be used for an extended period of time.</li></ul>
----------------	---

<b>Note</b>	<p>The Lithium-Ion battery is a rechargeable battery containing Lithium-Ion cells. Each battery contains an integrated electronic fuel gauge and a safety protection circuit.</p>
-------------	---

<b>Note</b>	<p>To keep the veterinary multiparameter monitor fully charged for patient transport, keep the veterinary multiparameter monitor plugged in until you are ready to transport the patient. Reconnect it to AC power immediately after transfer.</p> <p>Battery life depends on the frequency of use. Continued use by the battery power reduces the battery life and shortens the time of replacement.</p> <p>Be sure to recharge the battery before it is completely discharged.</p>
-------------	--

### How to replace the battery

Replace the battery as shown below.

If the battery of Brio X3VET does not fit in entirely, lay down the monitor with facing up and try again.

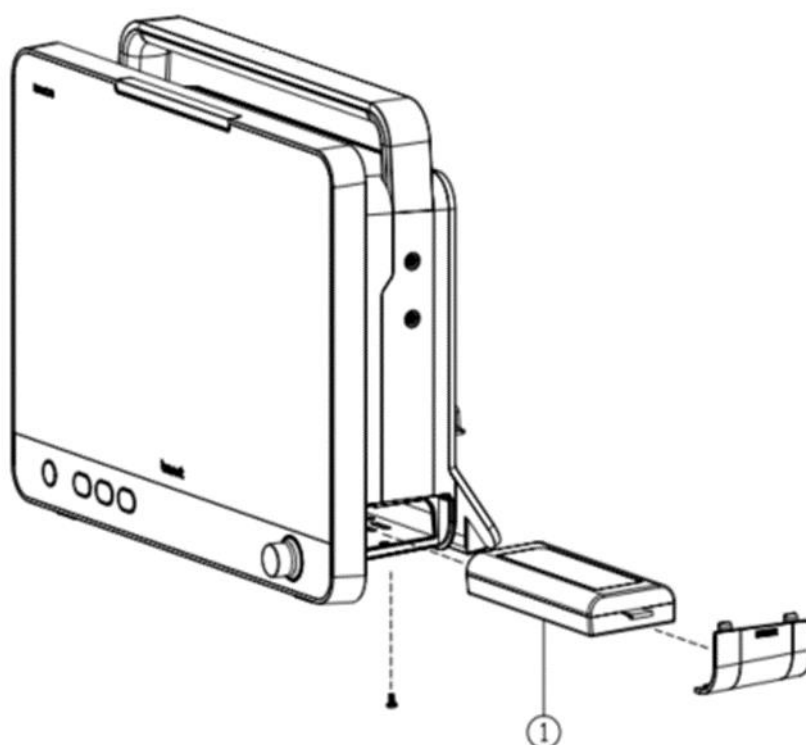

① Standard battery

### Warning

**Pay attention to the polarity when replacing the battery.**

**We strongly recommend the use of battery officially supplied by Bionet.**

**Ensure that the battery is properly secured to the bracket.**

**Do not inflict extreme levels of impact on the battery.**

**Ignoring the above warnings may cause battery explosion or other critical damages to the veterinary multiparameter monitor.**

### Conditioning Guideline

Check battery performance by fully charging and completely discharging it every 6 months.

### How to Recycle the Battery

When the battery no longer holds a charge, it should be replaced. The battery is recyclable. Remove

the old battery from the monitor and follow your local recycling guidelines.

<b>Warning</b>	<b>EXPLOSION HAZARD</b> <b>DO NOT incinerate the battery or store at high temperatures as it may explode, which may cause you serious injury.</b>
----------------	--

<b>Warning</b>	<b>Do not use the battery that has been impacted, disfigured, or submerged; dispose of it.</b>
----------------	--

## 8) Getting Started

### Starting the monitor

Press the power key at the bottom right of the monitor's front panel.

<b>Caution</b>	<ul style="list-style-type: none"><li>● <b>Check that the visual and audible alarm signals are displayed correctly when the veterinary multiparameter monitor is powered on.</b></li><li>● <b>Do not use the veterinary multiparameter monitor on a patient if you suspect it is not working properly or has been mechanically damaged. Contact your service representative or Bionet.</b></li></ul>
----------------	--

### Stopping the monitor

Press and hold the power key for 3 seconds, and the screen goes off.

### Main screen setup

After the monitor is turned on, the main screen is displayed.

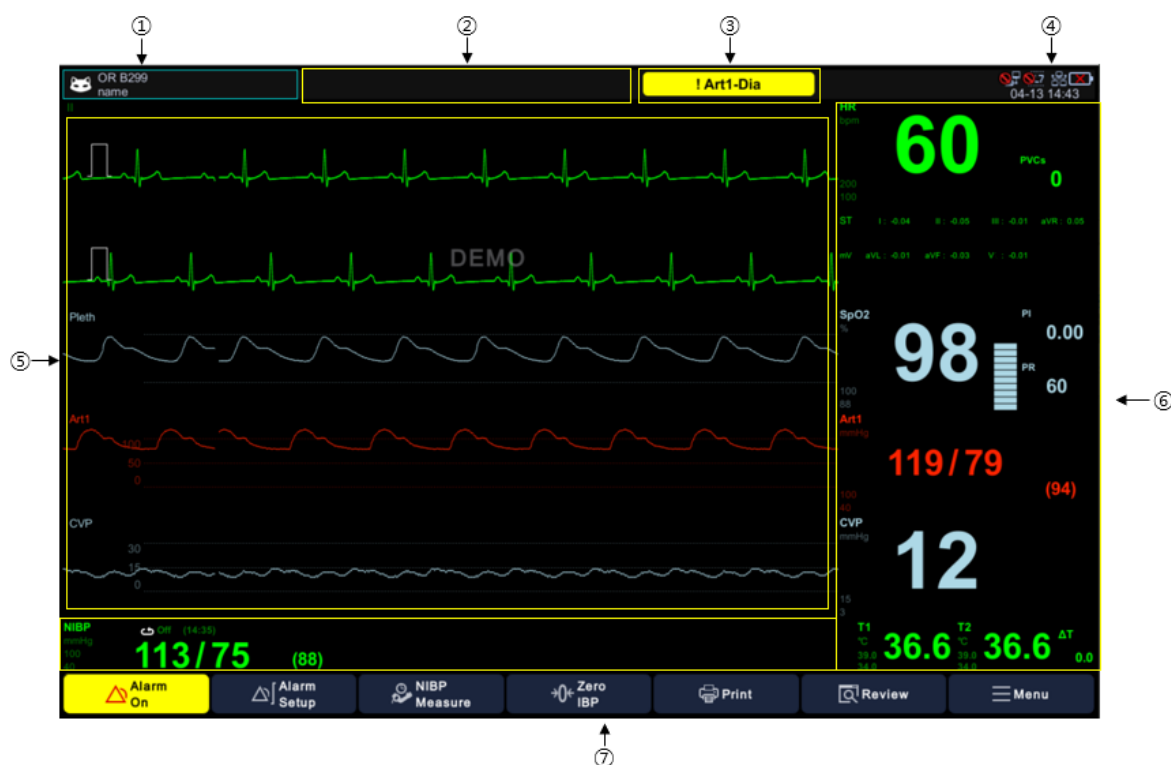

### Veterinary multiparameter monitor Screen Layout



- ① Patient information: Displays patient information (patient species and name), unit name, and bed number. If you tap this area, the patient management dialog appears.
- ② Alarm mode information: Mode information is displayed in this area when changing the alarm mode. In Paused mode, the remaining time is also displayed.
- ③ Bio-signal alarm message: Displays high-priority alarms from the right.
- ④ System Status Information: Displays time, power status, network, and server connection status.
- ⑤ Parameter waveform: Displays the parameter waveform. When you select a waveform, the corresponding setting window appears.
- ⑥ Parameter Numerical: Displays the parameter value, alarm range and alarm status. If you select a numerical area, the corresponding setting window appears.
- ⑦ Menu: Displays the menu.

## Rotary knob switch

The Rotary knob switch allows you to navigate menus, select settings, and perform menu functions. Rotate the Rotary knob to navigate the menu item. To confirm the selection, press the Rotary knob switch.

## Fixed keys

The fixed keys on the front panel of the monitor allow you to perform the frequently used functions.



Fixed key	Description
	<p>The alarm control key switches between Normal / Audio Paused/ Alarm Paused mode.</p> <p>Each time you press the key, alarm switches to Audio Paused -&gt; Alarm Paused -&gt; Alarm On.</p> <p>Press more than 3 seconds to switch to Audio Off or Alarm Off mode.</p>
	<p>It is the snapshot key.</p> <p>The data for 16 seconds right before the key is pressed is saved as a snapshot. You can view the saved snapshots in the Events menu of Review.</p>
	<p>It is the start or stop NIBP measurement.</p> <p>When the measurement is stopped, the automatic measurement cycle is also canceled.</p>







### Caution

**If the power key or fixed key is pressed hard with a fingernail, it may be torn or deformed.**

## Function keys

On the right side of the monitor's front panel, you can find the touch screen icons that allows you to select frequently used functions.

Function key	Description	Function key	Description
	Alarm mode key: Switch between Normal/ Audio		Set alarm conditions for each parameter.

	Paused/ Alarm Paused mode.		
	Automatic blood pressure measurement interval setting menu.		Zero the IBP. (Displayed only when the IBP parameter is on.)
	Start or stop printing when the printing is in progress. (Displayed only when a printer is connected.)		Review the stored data in the monitor, including trends, alarm events, snapshots, and full disclosure.
	Check other veterinary multiparameter monitors on the current monitor. (Only displayed if B2B Settings are turned on.)		It displays the setup menu.

## PART 2. Setup

### 1) Overview

This part describes how to configure the monitor.

### 2) Main Menu

Menu	Description	Available settings
<b>A. Change Layout</b>	Change the monitoring screen layout.	Waveform, Large Parameter, Popup Trend
<b>B. Demo</b>	Activate the demo mode.	On, Off
<b>C. Screen Lock</b>	<p>Enable user input lock.</p> <p>When input is locked, a lock icon is displayed in the center of the screen and the touch and keystrokes are disabled.</p> <p>You can unlock the input by touching the lock icon.</p>	On
<b>D. Display Setup</b>	Parameter view settings	
<b>D-1. Waveform Parameters</b>	Waveform Layout parameter setting Decide whether to display and select parameter colors.	* Parameter : ECG, Resp, SpO2, IBP1,2, EtCO2, Gas, NIBP, Temp
<b>D-2. Large Parameters</b>	<p>Set parameters of Large Parameter Layout.</p> <p>You can select a parameter to be placed on the split screen.</p> <p>The time parameter displays the current time and patient information in large format. When you select a time,</p>	<p>* option Parameters : IBP 3,4</p> <p>* Large Parameters only : Time</p>

	the parameter next to it is automatically turned off.	* Color: Refer to the parameter color table below
<b>E. System Information</b>	System information If the information cannot be read, "Not Ready" is displayed.	
<b>E-1. License</b>	License information	
<b>E-2. MAC address</b>	MAC address	
<b>E-3. SW, ECG, ITS, NIBP</b>	S/W or F/W version information	
<b>E-4. EtCO2</b>	EtCO2 Module Details	
<b>E-5. Gas</b>	View Anesthetic Gas (AG) Module Details	
<b>F. System Setup</b>	System settings	
<b>F-1. General</b>	General settings menu	
<b>F-1-1. Unit Name</b>	Monitoring group settings  The unit name is displayed in the patient information area.  The same group monitors can be connected thru B2B monitoring mode.  When USER DEFINE is selected, you can directly input the unit name.	ICU OR USER DEFINE
<b>F-1-2. Bed Number</b>	Bed number setting The bed number is displayed in the patient information area.	1~300
<b>F-1-3. Language</b>	Language settings	English, Korean French, Bulgarian Polish, German Chinese, Portuguese Hungarian, Czech Romanian, Italian Turkish, Spanish Russian, Greek Japanese, Dutch
<b>F-1-4. Touch Volume</b>	Touch sound settings	Off ~ 100%
<b>F-1-5. Screen Brightness</b>	screen brightness setting	10~100%
<b>F-1-6. Hospital Name</b>	Hospital name	

<b>F-1-7. Doctor Name</b>	Doctor name	
<b>F-1-8. Date Format</b>	Set date format	YYYY-MM-DD, MM/DD/YYYY, DD/MM/YYYY
<b>F-1-9. Patient Setup &gt; Patient Display</b>	Set patient information to be displayed in the patient information area.	Unit + Bed ID
<b>F-1-9-1. Patient Setup &gt; Barcode ID Length</b>	Limit the number of characters when entering an ID with barcode.  The set number is entered as ID. If the length of the characters entered into the barcode is longer than the set number, the excess characters are entered as the patient's name. When set to blank, all entered characters are entered as ID.	Blank (no input restrictions) 1-20 characters
<b>F-1-9-2. Patient Setup &gt; When Entering Barcode ID</b>	Set Admit action when entering ID with barcode.  Auto Admit: Admit immediately Manual Admit: The patient management window appears and you can directly admit after confirmation.	Manual Admit, Auto Admit
<b>F-1-9-3. Patient Setup &gt; Default setting at Admit</b>	Set default settings when admitting patients  When On, alarm and parameter settings are applied as manufacturer settings for the current patient species. When off, the last setting of the current patient species is applied.	On, Off
<b>F-1-9-4. Patient Setup &gt; Default setting at Discharge</b>	Set default setting when patient is discharged  When On, the alarm and parameter	On, Off

	settings are applied as the manufacturer's settings for dog. When off, the last setting for dog is applied.	
<b>F-1-10. AC Filter</b>	AC filter setting	Off, 50Hz, 60Hz
<b>F-2. Units</b>	Unit setting menu	
<b>F-2-1. Weight</b>	Weight measurement unit	kg lbs
<b>F-2-2. Height</b>	Height measurement unit	cm inch
<b>F-2-3. Blood pressure</b>	Blood pressure measurement unit	mmHg kPa
<b>F-2-4. ST</b>	ST measurement unit	mm mV
<b>F-2-5. Temperature</b>	Temperature measurement unit	°C °F
<b>F-2-6. Gas &gt; CO2</b>	CO2 unit selection	mmHg kPa %
<b>F-2-7. Gas &gt; N2O</b>	N2O unit selection	
<b>F-2-8. Gas &gt; O2</b>	O2 unit selection	
<b>F-2-9. Gas &gt; Anesthetic gas unit</b>	Anesthetic Gas (AG) unit selection	
<b>F-3. Date Time</b>	Date Time settings	
<b>F-3-1. Date &amp; Time</b>	Date Time setting	Year, Month, Day, Hour (24H), Minute, Second
<b>F-3-2. Apply</b>	Apply entered date and time	
<b>F-4. Network</b>	Network settings	
<b>F-4-1. Wireless</b>	Whether to use wireless	On, Off
<b>F-4-2. AP Search</b>	Execute the AP setting menu window. The SSID of the currently connected AP is displayed.	
<b>F-4-2-1. AP List</b>	Scanned AP list The SSID, signal strength, security information and connection status are displayed.	
<b>F-4-2-2. Connect</b>	Selected AP connection	

<b>F-4-2-3. Refresh</b>	AP list update	
<b>F-4-2-4. Add AP (+)</b>	Add network. Use if you manually add and connect hidden networks.	
<b>F-4-3. DHCP</b>	Auto IP allocation setting menu	On, Off
<b>F-4-4. IP</b>	IP manual Settings The set IP is displayed. It can be entered when DHCP is Off.	XXX.XXX.XXX.XXX
<b>F-4-5. Subnet Mask</b>	Subnet mask manual setting The set subnet mask is displayed It can be entered when DHCP is Off.	XXX.XXX.XXX.XXX
<b>F-4-6. Gateway</b>	Gateway manual setting The set Gateway is displayed. It can be entered when DHCP is Off.	XXX.XXX.XXX.XXX
<b>F-4-7. MAC Address</b>	Display Ethernet MAC address	
<b>F-5. Communication</b>	Server Settings	
<b>F-5-1. BT-Link &gt; Protocol Version</b>	The BT-Link protocol version information is displayed.	1.4.0
<b>F-5-2. BT-Link Next</b>	BT-Link Next activation	On, Off
<b>F-5-3. BT-Link Next IP</b>	BT-Link Next server IP address setting	XXX.XXX.XXX.XXX
<b>F-5-4. BT-Link Mobile</b>	BT-Link Mobile activation	On, Off
<b>F-5-5. BT-Link Mobile IP</b>	BT-Link Mobile server IP address setting	XXX.XXX.XXX.XXX
<b>F-5-6. B2B &gt; B2B</b>	B2B activation	On, Off
<b>F-5-7. HL7 &gt; HL7</b>	Enable HL7 integration.	On, Off
<b>F-5-8. HL7 &gt; Server IP</b>	HL7 Server IP Address Settings	XXX.XXX.XXX.XXX
<b>F-5-9. HL7 &gt; Port</b>	Remote PC Port Address	XXXX
<b>F-5-10. HL7 &gt; Period</b>	Message transmission cycle setting menu	10sec, 30sec, 1,3,5,10,15,30min, 1hour, 6 hour
<b>F-5-11. HL7 &gt; Check Response</b>	Setting up server response verification for sent HL7 messages An exclamation mark is displayed on the HL7 icon if the HL7 message transmission fails only when set to On.	On, Off
<b>F-5-12. HL7 &gt; Labels Edit</b>	Execute parameter LABEL edit menu	

	window.	
<b>F-5-12-1. Parameter 1</b>	Enter default parameter label.	ECG, SpO <sub>2</sub> , Resp, NIBP, EtCO <sub>2</sub> (EtCO <sub>2</sub> , FiCO <sub>2</sub> , AwRR label is used with Gas/EtCO <sub>2</sub> )
<b>F-5-12-2. Parameter 2</b>	IBP parameter label input	IBP
<b>F-5-12-3. Parameter 3</b>	Anesthetic Gas (AG) label input	AG
<b>F-5-12-4. Parameter 4</b>	Temp label input	Temp
<b>F-5-12-5. Unit</b>	Unit label input	Percent, mmHg, kPa, bpm, rpm, 'C, 'F, mm, mV
<b>F-5-12-6. Alarm Priority</b>	Alarm priority label input	High, Medium, Low
<b>F-6. Alarm</b>	Alarm setting	
<b>F-6-1. Alarm sound</b>	Alarm sound type	IEC60601 BIONET
<b>F-6-2. Alarm Paused Time</b>	Alarm paused time setting	1, 2, 3, 5, 10, 15 min
<b>G. Calibration</b>	Touch screen and parameter calibration.	
<b>G-1. Touch screen</b>	<p>Touch screen calibration</p> <p>1) Access the [Calibration] menu from the main menu, then select [Touch Screen Calibration].</p> <p>2) Press the cross markers on the Touch Calibration Screen in chronological order.</p> <p>3) Once the calibration is complete, the screen disappears.</p>	
<b>G-2. Parameter Calibration</b>	Chapter 2-3) Parameter Calibration Reference	

**warning**

**Do not use keys or menu navigation key (rotary knob) on the touch screen calibration screen.**

**note**

If the device's time does not match the current time, set the current time in the Date Time menu.

**Parameter colors**

Selectable Colors			
green, light blue, magenta, yellow, blue, sky blue, white, coral, scarlet, purple, orange, pale green, pink, pale yellow			
Parameter	Color	Parameter	Color
ECG (ST)	Green	SpO2	Light Blue
RESP	Yellow	NIBP	Magenta
TEMP	Green	ETCO2	Yellow
IBP1	Scarlet	IBP2	Light Blue
IBP3	Yellow	IBP4	purple
Gas(AG)	Yellow		

**3) Parameter Calibration**

Select Parameter Calibration from the Calibration menu. Manufacturer certification is required.

Menu	Description	Available settings
<b>A. ECG</b>	ECG Parameter Calibration Menu	
<b>A-1. ECG Calibration</b>	ECG calibration and last calibration time is shown.	10mm/mV Input calibration indication
<b>A-2. Resp Calibration</b>	Resp calibration and last calibration time is shown.	1ohm 1mm
<b>B. IBP</b>	IBP parameter correction menu	
<b>B-1. IBP1~4 Zero</b>	IBP# Zeroing and last zeroing time is shown.	
<b>B-2. IBP1~4 Calibration</b>	IBP# calibration and last calibration time is shown.	
<b>C. NIBP</b>	NIBP parameter correction menu	
<b>C-1. Zero Calibration</b>	NIBP Zero Calibration Menu	Air Pressure Zero Calibration
<b>C-2. Gain Calibration</b>	NIBP gain Calibration menu	
<b>C-3. Pneumatic pump</b>	NIBP Pump Adjustment Menu	On, Off

<b>C-4. Pneumatic valve</b>	NIBP Valve Adjustment Menu	Close, Open
-----------------------------	----------------------------	-------------

## 4) Maker Service

Here provided the functions used by manufacturers. Execute the Maker Service menu in the main menu. Manufacturer certification is required.

Menu	Description	Available settings
<b>1. Write MAC</b>	Save the MAC address. Enabled only if there is no stored MAC.	
<b>2. MAC address</b>	MAC address display	
<b>3. SD Card Format</b>	SD Card Format Clear and initialize all data and settings except for parameter calibration values, account information, and network settings.	
<b>4. Factory Reset</b>	Factory Reset Erase and initialize all data and setting values.	
<b>5. Erase Data</b>	Erase data. Clear trends, alarm events, and full disclosure data.	
<b>6. Reset Settings</b>	Reset setting values.	
<b>7. Reset Admin</b>	Initialize the Admin password, which is the default account.	
<b>8. eMMC Info</b>	View eMMC status information.	
<b>9. Export Settings</b>	Export system and alarm setting files to USB memory.	
<b>10. Import Settings</b>	Import system and alarm setting files in USB memory to the device.	
<b>11. F/W Download</b>	Upgrade the firmware.	

**Note**

When using the export settings, import settings, and F/W download menus, be sure to connect only one USB memory.

---

# PART 3. Network

## 1) Overview

When the veterinary multiparameter monitor is connected to the network, it can be accessed remotely through other veterinary multiparameter monitors or the central station.

BT-Link Next connects multiple veterinary multiparameter monitors to the central station and allows the remote control of the connected veterinary multiparameter monitors for various settings as well as patient data management.

The functions that can be remotely controlled from BT-Link Next are as follows.

- Patient admit and discharge
- Alarm condition setting
- Alarm status
- Display settings
- Start or stop NIBP measurement

The monitor's B2B View (Bed to Bed View) feature allows you to view other monitor screens connected to the network and to silence remote control and alarms [Audio Paused].

Only one device can be monitored and controlled at a time. The functions that can be remotely controlled from B2B View are as follows.

- Display settings
- Start or stop NIBP measurement

To set monitor's network and activate BT-Link Next and B2B function, please refer to **F-4. Network and F-5 at the PART 2.**

**Warning**

**BT-Link Next cannot act as a primary alarm device and cannot rely on alarm notifications. There may be no audible or visible indications other than what is displayed on the screen, and the data displayed may be delayed.**

## 2) Network Connection

In a network, data can be transferred over wired or wireless connection.

All data interfaces (e.g., LAN, USB interface) follow the standard network procedure. Brio XVET series can exchange patient data with other Brio XVET monitors through the network during operation and supports the following functions.

- Display waveform and parameter data
- Alarm signals
- Remote control (e.g., alarm management)
- Device setup and patient data transmission

When Brio XVET series are connected to the network with other devices, if there are any changes in the network, it could impose risks to patients, users, and third parties. These risks must be identified, analyzed, and evaluated before the monitor is connected to the network or before the network is changed, and appropriate measurement must be carried out.

Subsequent changes to the network examples are:

- Network configuration change
- Removing a device from the network
- Adding new devices to the network
- Upgrading or updating devices connected to the network

**Warning****Recommendations for wireless connections**

- **The veterinary multiparameter monitor connected to the network could vary depending on wireless AP (Access Point) performance.**

- When using a general AP, it is recommended to connect no more than 8 units to the same network.
- Due to the characteristics of wireless connection, the connectivity might not be stable depending on the environmental interferences.

**Supported USB Wi-Fi Dongle**

The veterinary multiparameter monitor supports the following USB VID and PID dongles.

USB VID:PID
2357:0120
2357:011e, 2357:0122
2357:011f
0bda:0811, 0bda:0821, 0bda:8822, 0bda:a811
2357:010d
148f:761a
0e8d:7650
148f:7601
0bda:8176

**Note**

The veterinary multiparameter monitor has completed the testing of the USB Wi-Fi dongle as follows.

**TP-Link**

Model	USB VID:PID	chipset
TP-LINK T2U nano	2357:011e, 2357:0122	Realtek 8821a
TP-LINK T2U v3	2357:011f	Realtek 8821a
Etc 8821A MODEL	0bda:0811, 0bda:0821, 0bda:8822, 0bda:a811	Realtek 8821a
TP-LINK T2UHP	2357:010d	MediaTek 7650u

TP-LINK T2U	148f:761a	Ralink 7610u
TP-LINK T2UH	148f:761a	Ralink 7610u
TP-LINK T2U v2	0e8d:7650	MediaTek 7650u
TP-LINK AC600 archer T2U	2357:011f	Realtek 88XXau
TP-Link TL-WN727N v4	148f:7601	Ralink 7601U

**ip Time**

Model	USB VID:PID	chipset
ipTime N150UA	148f:7601	Ralink 7601U
ipTime N100mini (N300U / Ncubic )	0bda:8176	Realtek 8188CU/8192CU

Even if the USB VID and PID dongles are listed above, dongles that have not been tested by the company may not be supported.

**Note**

Intermittently, the USB Wi-Fi dongle may not be recognized, the AP list may not appear, or communication may be interrupted. In this case, remove the dongle from the device and reconnect it.

If the problem persists even though the network settings are normal, replace the Wi-Fi dongle.

**Note**

The veterinary multiparameter monitor is compatible with BT-Link Next v4.00 or later.

### 3) IT Network Connection

As only the authorized personnel can connect the veterinary multiparameter monitor to the network, consult with the IT staff in the hospital at the time of installation.

Please refer to the following documents to proceed with the installation.

- Documents attached to this unit

- Network Interface Manual
- BT-Link Next user documentation

We recommend following IEC 80001-1 (Hazard Management of IT Networks Connected with Medical Devices).

## 4) LAN Network

LAN networks are usually configured through a star topology. Individual devices can be combined into groups via a layer-n-switch. Other data traffic is separated by individual VLAN networks. Configure the device's network settings according to this manual and your network specifications. LAN connection specifications are described in the following standard standards.

LAN connection specifications are described in the following standard specifications.

- Wired Network: IEEE 802.3
- Wireless network: IEEE 802.11 (a, b, g, n)

If the monitor is to be used as a layer-2-switch or layer-3-switch, the port setting must be configured on the network switch. Configure the network of Bionet devices to be compatible with the specifications of your operating organization.

The veterinary multiparameter monitor exchanges data with other medical devices over a LAN network. The network must support the following transports and protocols:

- TCP / IP
- Broadcast

## 5) VLAN Network

If data is exchanged within a single network, you must establish an independent VLAN network for clinical information systems. At least one of the following independent VLAN networks must be established.

- Network for medical devices in hospital
- Network for portable veterinary multiparameter monitors

Also, you should build a network system that detects and defends against denial-of-service attacks by establishing a system dedicated to DDos protection.

## 6) Inappropriate Network

If your network does not meet the requirements, the following risk factors can occur.

If the distributed alarm system is not safe:

- The alarm is not delivered.
- The alarm or data is delayed.
- An error alarm appears.

If the network connection is interrupted:

- The alarm is not delivered.

If you do not have firewall and antivirus software:

- Your data is not protected.
- The device settings may be changed.
- The device raises an error alarm or does not generate an alarm.
- Data is being sent incomplete, to the wrong device, or not at all.
- Patient data is blocked, falsified, or corrupted.
- The time stamp of the data is inaccurate.

Excessive over-loading due to very high network loading (e.g., denial of service attacks) can cause interface deactivation. The interface can only be used again after the device is restarted. Rarely, booting may be slow and repeated rebooting may occur.

## 7) B2B View

If a monitor is connected to the network, you can access other monitors in the same network by using the B2B menu at the bottom to see the real time data and silence alarms when needed.

Press  B2B menu to activate B2B screen.

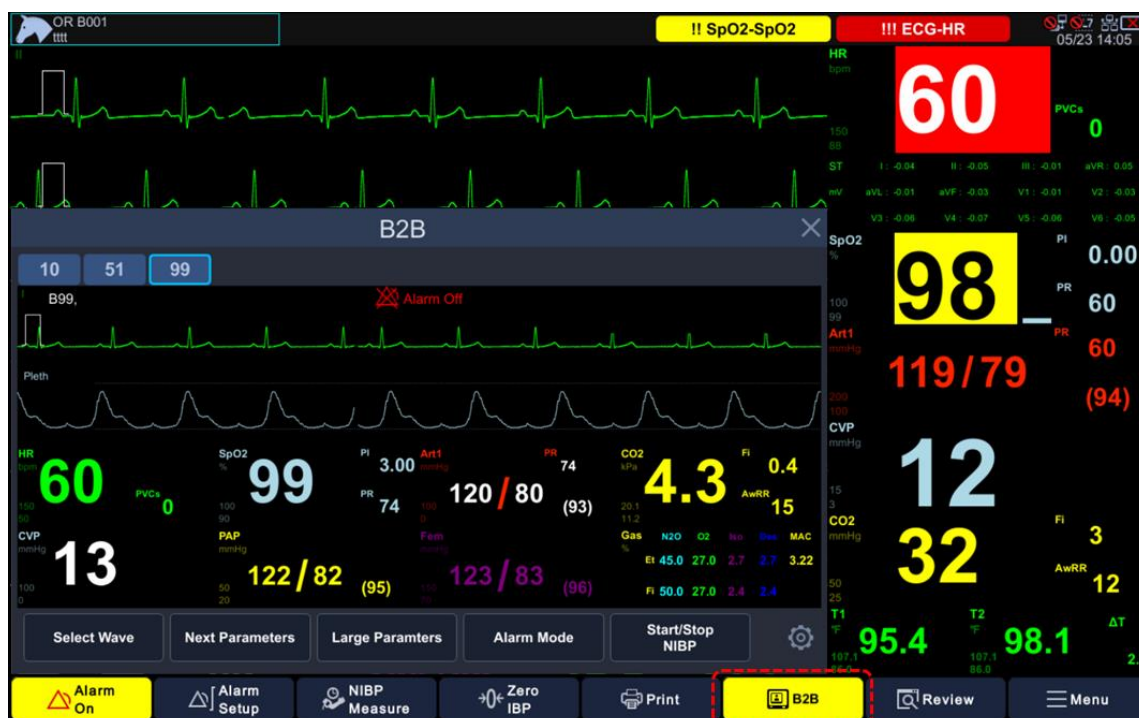

At the top of the B2B screen, a list of BEDs using the same Unit Name is shown.

The BED in which an alarm has occurred displays the highest alarm level in the background color.

B2B can be operated with up to 16 monitors including the main one.

Use the settings menu to view the information about the beds in detail.

<b>Note</b>	<ul style="list-style-type: none"> <li>● Even if in the same network, if the Unit Name of a bed is different, the bed does not appear in the B2B list. If it does not appear in the B2B list, check the network settings and Unit Name of the veterinary multiparameter monitor.</li> <li>● The veterinary multiparameter monitor's unit name and Bed information</li> </ul>
-------------	--

is displayed in the patient information area.

### Waveform Layout

Two waveforms and numerical values are displayed together. (Brio X3VET displays one waveform)

You can use the Select Wave menu to change to a waveform with different parameters.

Use the Next Parameters menu to view the values of other parameters.

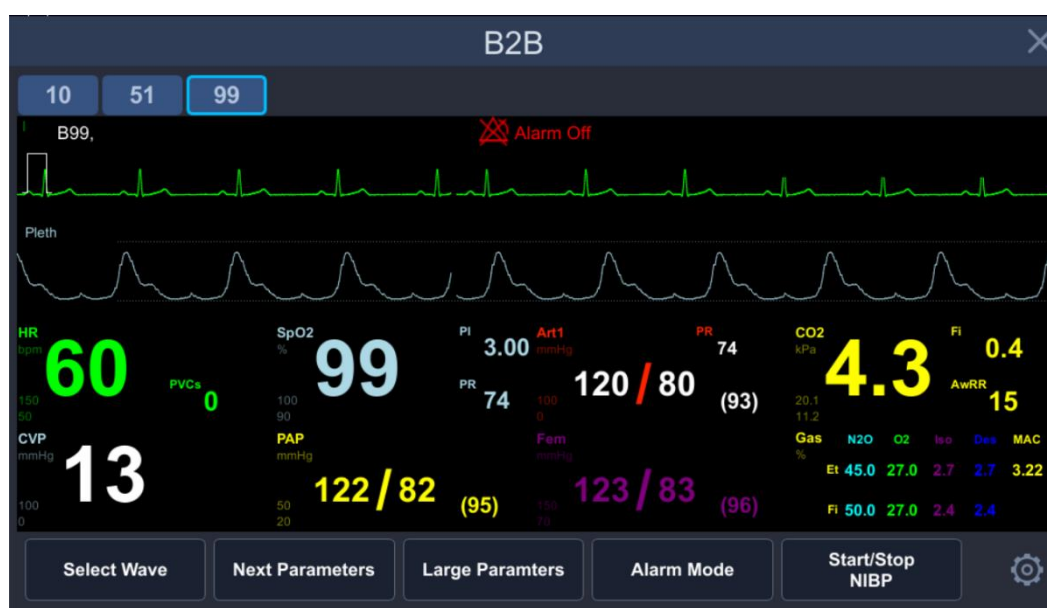

### Large Parameter Layout

Parameter values are displayed in large size.

Use the Next Parameters menu to view the values of other parameters.



## Bed Control

You can control the bed being monitored by using Alarm Status and Start/Stop NIBP menus.

## 8) B2B Settings

Menu	Description	Available settings
1. Bed list	Can display up to 16	
2. B2B Window	Data display of the selected bed Composed of 2 waves, numeric parameters Display bed number, patient name, alarm mode	ECG, SpO2, RESP, EtCO2, IBP1, IBP2, IBP3, IBP4 Gas(AG)
3. Select Wave	ECG channel selection Selectable when Trace1 or Trace2 is ECG.	I / II/ III/ aVR/ aVL/ aVF/ V
4. Next Parameters	View the next parameter (If you read all the way to the last chapter, come back to the first chapter.)	
5. Large Parameter / Waveform	layout change	Large Parameter, Waveform

---

<b>6. Alarm Status</b>	Change the alarm status of the selected bed	Alarm On, Audio Paused, Alarm Paused, Audio Off, Alarm Off
<b>7. NIBP Start/Stop</b>	Start and stop NIBP measurement of the selected bed	Start Stop
<b>8. Setup</b>	Bed list information See details	

## PART 4. Admission and Discharge

### 1) Overview

When a patient is connected to the monitor, it displays the patient's physiological data so that the patient can be monitored without hospitalization. However, since the monitor's alarm generation and trend data storage require the patient to be hospitalized, managing the patient's admission and discharge is important. The patient management menu enables you to manage the patient's admission, discharge, and patient information. The monitor displays the set unit and Bed information along with the information of a hospitalized patient and ID information..

Patient admission and discharge can be managed also from the central monitoring unit (BT-Link Next).





### 2) Admitting a Patient

Admit a patient to the hospital at the beginning of veterinary multiparameter monitoring. Upon admission, set an alarm condition with the current patient species and activate the alarm. Bio signal data is saved as trend data for the current patient.

#### How to admit a patient:

-  Press the **[Patient]** icon button.
- Enter patient information** (Patient species, ID, name, age) on the Patient Management dialog.  
  
If the same patient information as the entered ID already exists, the patient information is displayed on the screen.
- Press the **[OK]** button to confirm the admission.

When the patient is admitted, the icon in the Patient Management menu changes as the following chart.

Species	Admit	Discharge
Dog		
Cat		
Horse		
Others (small animal)		

**Note**

- The default animal species is Dog.
- You can change the animal species (Dog, Cat, Horse, Others) in the patient management dialog.
- If you change the patient species, the monitor is reset to the previous set value of the selected species. To return the set value to the manufacturer's default setting, execute the "Default Settings" menu on the patient management dialog.

### 3) Editing Patient Information

Correct or add additional information about hospitalized patients.

1.  Press the [Patient] icon button.
2. Enter patient information such as patient species, ID, name, and age on the Patient Management screen.
3. Press the [OK] button to update patient information.

**Note**

If you change an ID of a patient, the patient is discharged and readmitted with the changed ID.

## 4) Discharging a Patient

To terminate the monitoring of hospitalized patients, or admit new patients, discharge the current. Once a patient is discharged, trend data is not be saved any more.

**How to discharge a patient:**

1.  Press the [Patient] icon button.
2. Press the **Discharge** menu. You can show Discharge confirm message
3. Press the **[Yes]** button. The discharge procedure is in progress.

When the patient is discharged successfully, Patient icon () changes to Discharge status.

### Warning

**You must discharge the current patient before admitting a new patient. Otherwise, the data may be associated with the wrong patient.**

### Note

**Upon discharge, the patient monitor resets to the previous dog settings.**

## 5) Patient Management Menu

Menu	Description	Available settings
<b>1. Species</b>	Set the animal species (type)	Horse, Dog, Cat, Others (small animals)
<b>2. Patient ID</b>	Enter ID	
<b>3. Auto</b>	Automatic ID generation  An ID is automatically generated based on the current time.	
<b>4. Patient Name</b>	Enter the animal's name	
<b>5. Client Name</b>	Enter the guardian's name	

<b>6. Gender</b>	Enter gender	Male, Female
<b>7. Age</b>	Enter age	
<b>8. Age Unit</b>	Age unit setting	Years, Weeks, Days
<b>9. Weight</b>	Enter animal's weight	XXX.XX kg (lbs)
<b>10. Admit/Discharge</b>	Patient admit/discharge	
<b>11. Default Setting</b>	Reset alarm and parameter settings to the manufacturer settings of the current animal species.	
<b>12. Ok</b>	Update entered patient information.  The patient species and name are displayed in the patient information area.	
<b>13. Cancel</b>	Cancel patient information update and close dialog.	

## 6) Registering Patient ID Using Barcode

The monitor can register the PATIENT ID in barcode format using a USB barcode scanner. First, connect the barcode scanner to the USB port on the back of the monitor as shown below. When you hear a beep, the barcode can be used.

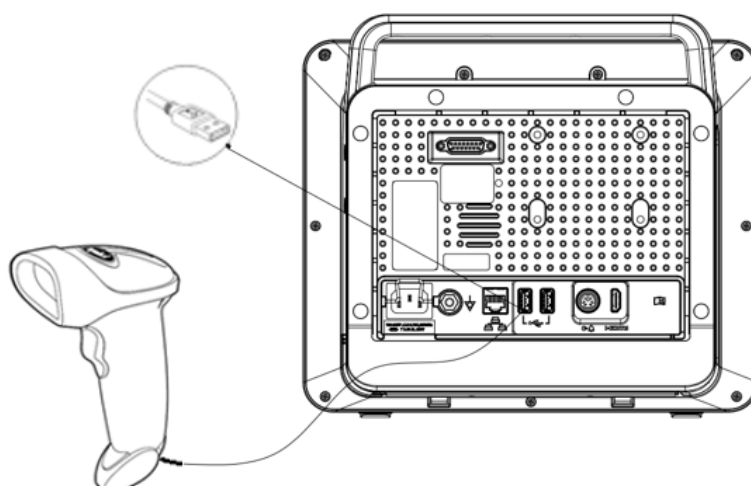

When you press the button on the barcode reader to scan the patient ID, the patient management dialog appears and displays the scanned ID and corresponding patient information.

## PART 5. Alarm

### 1) Overview

The monitor displays the alarm limit (parameter threshold) and can be configured to occur an alarm if exceeded limits are detected both in the alarm limits table and in the parameter box. If this limit is exceeded, a visual or audible alarm occurs.

Once the monitor's alarm and other parameter setting values are set, unless a separate operation is performed, they remain same even if the monitor power is turned off. After connecting the power to the monitor and turning it back on, it starts to operate normally, and the alarm and other parameter values keep the set values.

<b>Warning</b>	<b>A potential hazard can exist if different alarm presets and default configuration settings are used for the same or similar devices in the same care area: for example, an intensive care unit or cardiac operating room.</b>
<b>Note</b>	<b>When the veterinary multiparameter monitor is connected to BM central Pro, an alarm signal is expected be delayed around 2 seconds from the veterinary multiparameter monitor to the BT-Link Next.</b>

### 2) Alarm Priority

According to the severity of the alarm, it is divided into high priority, medium priority, and low priority.

If multiple alarms occur at the same time, the monitor displays the highest priority alarm sound with a light.

- High Priority (High)

When the patient has a life-threatening clinical condition where the risk must be managed immediately, or the monitor is in a critical failure condition and the patient's life may be at risk because the patient's fatal condition cannot be detected.

- Mid Priority (Medium)

When the patient's physiological signs are abnormal and appropriate action or treatment is needed immediately, but not endangering to the patient's life. Or when the monitor is

severely malfunctioning and may affect the normal monitoring of key physiological parameters.

- Low Priority (Low)

The patient's physiological symptoms are abnormal and may require appropriate action or treatment or when a specific function of the monitor is malfunctioning, but the patient's life is not in jeopardy.

- Message (Message)

Circumstances that require notification regarding the condition of the patient or monitor

The audible alarm tones according to the alarm priority are as follows.

Audible Alarm		
Alarm priority	BIONET	IEC
High	1 high tone every 10 seconds	10 consecutive beeps every 10 seconds
Medium	1 high tone every 15 seconds	3 consecutive beeps every 15 seconds
Low	1 low tone every 30 seconds	2 consecutive beeps every 30 seconds

**Note**

- The alarm signal sound pressure level is 55 dB (A) to 85 dB (A) within a range of 1 meter.
- Refer to the F-6 Alarm, PART 2 about setting the audible alarm sound.

### 3) Alarm Type

The alarm priority is divided into a patient status (physiological alarm) and monitor status (technical alarm).

#### Physiological Alarm Screen

It occurs when a patient's physiological parameters exceed the alarm limits, or the patient is

physiologically abnormal. When a bio signal alarm occurs, the corresponding parameter blinks, and information is displayed in the bio signal alarm message area at the top of the screen.

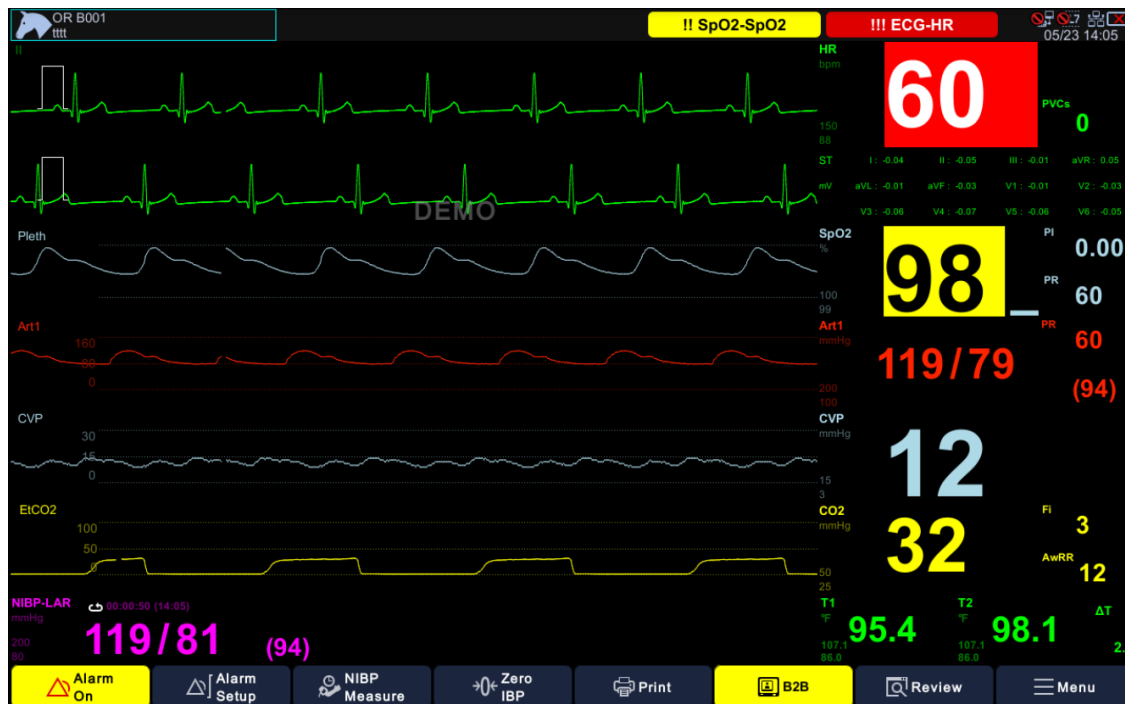

The alarm indications according to its alarm priority are shown as follows

Alarm priority	Alarm sound	Numeric window	Alarm lamp	Alarm Message
High	10	<b>RED</b> Blinking 1 time every 2 sec	Blinking 2 times every 1 sec	<b>RED</b> Prefix: !!!
Medium	3	<b>YELLOW</b> Blinking 1 time every 2 sec	Blinking 1 time every 2 sec	<b>YELLOW</b> Prefix: !!
Low	2	<b>YELLOW</b> Blinking 1 time every 2 sec	No blinking.	<b>YELLOW</b> Prefix: !

numbers : Alarm sound indication and number of beeps



: Alarm indicator in red on the screen



: Alarm indicator in yellow on the screen



: Alarm lamp in red



: Alarm lamp in yellow

### Technical Alarm Screen

Technical alarms are caused by improper operation or conditions that result in monitor failure or distortion of monitoring results. When a technical alarm occurs, the information is displayed in the corresponding parameter area.



Technical alarm table

Alarm priority	Alarm sound	Numeric window	Alarm lamp
Low		<b>BLUE</b> Blinking 1 time every 2 sec	No blinking.

Message		 Blinking 1 time every 2 sec	
---------	--	---	--

 numbers : Alarm sound indication and number of beeps

 : Alarm indicator in blue on the screen

 : Alarm lamp in cyan

## 4) Alarm Status

The monitor provides five different alarm conditions. Different icons indicate the current alarm status. You can adjust the alarm status by using the alarm status key or the alarm status menu.

### Alarm management

- Alarm Status Key

Press the  pausing key to adjust the alarm status.

A short press of the alarm control key circulates through the Audio Paused -> the Alarm Paused -> the Alarm On modes.

Press and hold the key for more than 3 seconds to switch to Alarm Off / Audio Off mode using the mode selection dialog regardless of which alarm mode the monitor is currently in.

- Alarm Status Menu

Press  the yellow menu at the bottom left of the screen.

Each time you press it, the status switches between Audio Paused -> Alarm Paused -> Alarm On.

## Alarm Status Display

Alarm status is displayed in the alarm status information area at the top of the screen and in the alarm status menu.



### Audio Paused

The audible alarm stops for 1 minute while the visual alarm is still activated. A window notifying that the audio has paused appears on the screen, along with the remaining time of the Audio Paused. When you press the alarm button or after the timeout period has elapsed, visual and audible alarms are activated again.



### Alarm Paused

The visual and audible alarms stop during user defined time. Alarm Paused message and countdown timer are shown in the alarm status area on the top of the screen. When you press the alarm button for another alarm mode or after the timeout period has elapsed, visual and audible alarms are activated again.

You can set the pause time in **F-6 Alarm** in the main menu.



### Audio Off

The audible alarm stops. Audio Off. Alarm window with audible sound is Off and shown on the screen. The monitor maintains Audio Off mode until you switches to another alarm mode.



### Alarm Off

The visual and audible alarms stop. Alarm Off. Alarm window with audible sound is Off and shown on the screen. The monitor maintains Alarm Off mode until user switches to another alarm mode.

#### Warning

- **When the alarm sound is switched off, the veterinary multiparameter monitor gives no alarm tones even if a new alarm occurs. Be careful when considering switching off the alarm sound.**
- **When the alarms are off or while alarm audio is paused either temporarily or indefinitely, observe the patient frequently.**

Note	<ul style="list-style-type: none"> <li>● <b>Alarm Paused and Off modes only stop the audible alarm sound. Touch and key sounds are still heard. To adjust the Touch or Key Sounds, use the Key Sound menu in Setup.</b></li> <li>● <b>When the connection with the central monitoring device (BT-Link Next) is cut when the alarm sound is off (Audio Off), it switches to the alarm on (Alarm On).</b></li> </ul>
------	--

## 5) Setting an Alarm

Press the  icon to pop up the alarm setting menu.

Changed alarm settings are maintained even if the monitor is suddenly turned off due to a power shortage, etc.

To return the alarm settings to the manufacturer's default settings, run the "Default Setting" menu on the Patient Management dialog (See **PART 4, Patient Management Menu**).

Menu	Description	Available settings
<b>A. Alarm</b>	Alarm, level, action setting menu for each parameter	
<b>A-1. Parameter List</b>	List of Parameters  Only the currently displayed parameters are displayed.  Select a parameter to display the alarm. setting menu.	Parameters : ECG, SpO2, Resp, EtCO2, Temp, NIBP, IBP1&2, Gas (AG)  Optional parameters : IBP 3&4
<b>A-2. Alarm</b>	Set whether to detect an alarm.	On, Off
<b>A-3. Priority</b>	Set alarm priority.	High, Medium, Low
<b>A-4. Low</b>	Set alarm lower limit.	
<b>A-5. High</b>	Set alarm upper limit.	
<b>A-6. Print</b>	Set print when an alarm occurs.	On, Off
<b>B. Arrhythmia</b>	Arrhythmia alarm level, action setting menu	
<b>B-1. Arrhythmia List</b>	List of arrhythmias	Asystole, V-Tach, V-Tach/V-Fib, Bigeminy, Trigeminy, Acc Vent, Couplet, Irregular,

		Pause, R on T, V-Brady, Short Run, PVC
<b>B-2. Alarm</b>	Set whether to detect an alarm.	On, Off
<b>B-3. Priority</b>	Set alarm priority.	High, Medium, Low
<b>B-4. Print</b>	Set print when an alarm occurs.	On, Off
<b>B-5. Off</b>	Turn off all arrhythmia alarms.	
<b>B-6. Lethal</b>	Turn on Asystole, V-Tach, V-Tach/V-Fib alarms only	
<b>B-7. Full</b>	Turn on all arrhythmia alarms.	
<b>C. Setup</b>	Alarm setting menu	
<b>C-1. Alarm volume</b>	Alarm volume setting	10~ 100%

**Warning**

- **Check the saved alarm setting of the veterinary multiparameter monitor in advance to ensure that the current setting is appropriate for the patient.**
- **Do not rely exclusively on the audible alarm system for monitoring. Adjustment of alarm volume to a low level may result in a hazard to the patient.**

## 6) Alarm Events

When a bio signal alarm occurs, data for a total of 16 seconds is saved for 8 seconds before and 8 seconds after the alarm occurrence. You can check the alarm events in the Events screen of the "Review" menu (.

The Events screen shows up to 1000 alarms in chronological order with the most recent occurrence. The list shows the alarm occurrence time, priority, and description.

You can select an item to view in detail, print, or delete.



**Note**

- Alarms are saved per events and is maintained even if the veterinary multiparameter monitor is powered down. The time of powering down the veterinary multiparameter monitor is not recorded as an event and cannot be reviewed.
- Earlier events are overwritten by recent events if the maximum storage of 1000 list is reached.

- **A total loss of power does not affect the events already stored.**

### Manual Event



If necessary, you can manually save the event by pressing the [Snapshot] key (  ) on the front of the monitor. In this case, data is saved for the 16 seconds immediately before the Snapshot key is pressed. You can check the saved manual events on the Events screen of the Review menu, which are marked as Manual Event with Message priority.

### Testing Alarms

On the demo mode, you can test the alarm tone and the alarm lamp by changing the alarm range and the alarm level. We recommend you to test the alarms every day.

#### Note

**When using the veterinary multiparameter monitor, we recommend you to operate it from the front.**

# PART 6. Trend

## 1) Overview

The monitor stores trend data for all connected signals. Trend data can be retrieved in the form of a table or graph and printed out or exported in the form of a csv file to a USB memory.

Trends can be stored for up to 168 hours, and old data is deleted when the storage capacity is exceeded.

Two trend modes (Graphic / tabular) are available at the Review menu (🔍).

## 2) Tabular Trend

The tabular trend tables display the trend data in an easy-to-read table format. Up to six lists are shown and updated every minute. The time stamp above each column indicates the interval at which the data in that column was saved. The displayed value is the recently acquired data during the interval, and the most recent data is shown in the right column. Alarm events that occurred within the time interval displayed on the screen are displayed as a red inverted triangle above the Timeline.



- ① Tabular Trend tab
- ② Graphic Trend tab
- ③ Event tab
- ④ Full Disclosure tab
- ⑤ Event List menu
- ⑥ Patient information
- ⑦ Event list navigation button
- ⑧ Tabular Trend Setting button
- ⑨ Tabular Trend Printer button
- ⑩ Export trend data
- ⑪ Selection navigation window
- ⑫ Trend interval setting menu
- ⑬ Parameter select button

When you select the  Review menu in the menu screen area, the Review screen appears. Select the Tabular Trend tab.

Menu	Description	Available settings
<b>1. Patient information</b>	The information of a patient admitted during the time zone where the cursor is positioned. Patient species, ID and Name	
<b>2. Event list</b>	Alarm event list up When you select an event, the cursor moves to that event time.	
<b>3. Move prev/next event</b>	The cursor moves to the previous/post event.	
<b>4. Time header</b>	The trend table is divided into 6 columns	1 column = Interval

	and the time zone is displayed. In case of an alarm, an alarm marker is shown at the corresponding position.	
<b>5. Parameter List</b>	Parameter name and unit display	
<b>6. Parameter Table</b>	The parameter name, unit, and numeric value of cursor position is displayed.	
<b>7. Move first page/prev page/prev line, Move last page/next page/next line Navigation slider</b>	Move section and update tabular trend.	
<b>8. Page up/down</b>	Page up/down	
<b>9. Interval</b>	Trend data interval	1 min, 5 min, 10 min, 15 min, 30 min, 1 hr, 2 hrs
<b>10. Setup</b>	Select parameters to display.	Note on Trend settings
<b>11. Print</b>	Print tabular trend data from the current time zone to the patient change (activated when printer is connected).	
<b>12. Trend Export</b>	Export the trend data.	Note on Trend file export

### 3) Graphic Trend

Graphic trend shows the saved trend data with individual graph type for each parameter. These graphs show that the displayed parameters are active over a significant period, five channels at a time. Confirmed color and scale meter labels and numbers are shown on the left side of the trend channel. Vertical lines show each graph, which displays the time of distribution. Alarm events that occurred within the time interval are displayed as a red inverted triangle above the Timeline.



- ① Tabular Trend tab
- ② Graphic Trend tab
- ③ Event tab
- ④ Full Disclosure tab
- ⑤ Event List menu
- ⑥ Patient information
- ⑦ Event List navigation button
- ⑧ Graphic Trend Setting button
- ⑨ Graphic Trend Printer button
- ⑩ Export trend data
- ⑪ Selection navigation window
- ⑫ Graphic trends zoom menu
- ⑬ Parameter select button

When you select the  Review menu in the menu screen area, the Review screen appears. Select the Graphic Trend tab.

Menu	Description	Available settings
<b>1. Patient information</b>	The information of a patient admitted during the time zone where the cursor is positioned. Patient species, ID and Name	
<b>2. Event list</b>	When you select an event, the cursor moves to the point of alarm event	
<b>3. Move prev/next event</b>	The cursor moves to the previous/post event.	
<b>4. Time header</b>	The graphic trend table is divided into 6 columns and the time zone is displayed. In case of an alarm, an alarm marker is shown at the corresponding position. In the corner, the cursor position time is shown.	
<b>5. Parameter List</b>	The parameter name, unit, and numeric value of cursor position is displayed.	
<b>6. Parameter Graph</b>	The parameter data is displayed according to the number of graphs in setting.	
<b>7. Move first page/prev page/prev line, Move last page/next page/next line Navigation slider</b>	Move section and update graph.	
<b>8. Page up/down</b>	View before/after page.	
<b>9. Zoom</b>	Change the resolution of the graphic trend table.	30 min, 1hr, 1.5 hrs, 2 hrs, 3 hrs, 4 hrs, 6 hrs, 8 hrs, 12 hrs
<b>10. Setup</b>	Select parameters to display.	Note on Trend settings

<b>11. Print</b>	Print the graphic trend data of the current time zone (activated when printer is mounted).	
<b>12. Trend Export</b>	Export the trend data.	Note on Trend file export

## 4) Setting Trend

Set the parameters to be displayed.

Menu	Description	Available settings
<b>1. Zoom</b>	Trend resolution settings (trend time range settings)	30min, 1hr, 1.5hrs, 3hrs, 6hrs
<b>2. Original Parameter List</b>	Available parameter list	
<b>3. Selected Parameter List</b>	List of parameters to display at the trend table	
<b>4. Add</b>	List of parameters to add at the trend table	
<b>4. Add All</b>	Move all Original Param List to Selected Param List.	
<b>5. Remove</b>	Move selected Param item to Original Param List.	
<b>6. Remove All</b>	Move all Selected Param Lists to Original Param List.	
<b>7. Move Top</b>	Move the selected Param item to the top.	
<b>8. Move Up</b>	Move the selected Param items up one.	
<b>9. Move Down</b>	Move the selected Param items down one.	
<b>10. Move Bottom</b>	Move the selected Param item to the bottom.	
<b>11. Close</b>	Save Settings + Close Window.	

## 5) Exporting a Trend file

You can use the file extract function to transfer trends to a file using a USB memory device.

1. Connect a USB memory device.
2. Set a start time, end time, export time, and export order.
3. Press [Export] button.
4. A completion message is displayed when the transmission is completed.

Menu	Description	Available Settings
1. Start/ End Time	Start/end time of trend data	
2. Interval	Trend data interval	1 min, 5 min, 10 min, 15 min, 30 min, 1 hr
3. Order	Sort order	Ascending, Descending
4. Patient	Select Patient ID Used to extract trend data for a specific patient.	All, Patient ID
5. Export	Export	

**Note**

The file format of USB memory supported by Brio series is FAT32.

## 6) Popup Trend

When selecting Popup Trend Layout from the Change Layout menu of the main menu, you can view and monitor the latest trends at the same time.

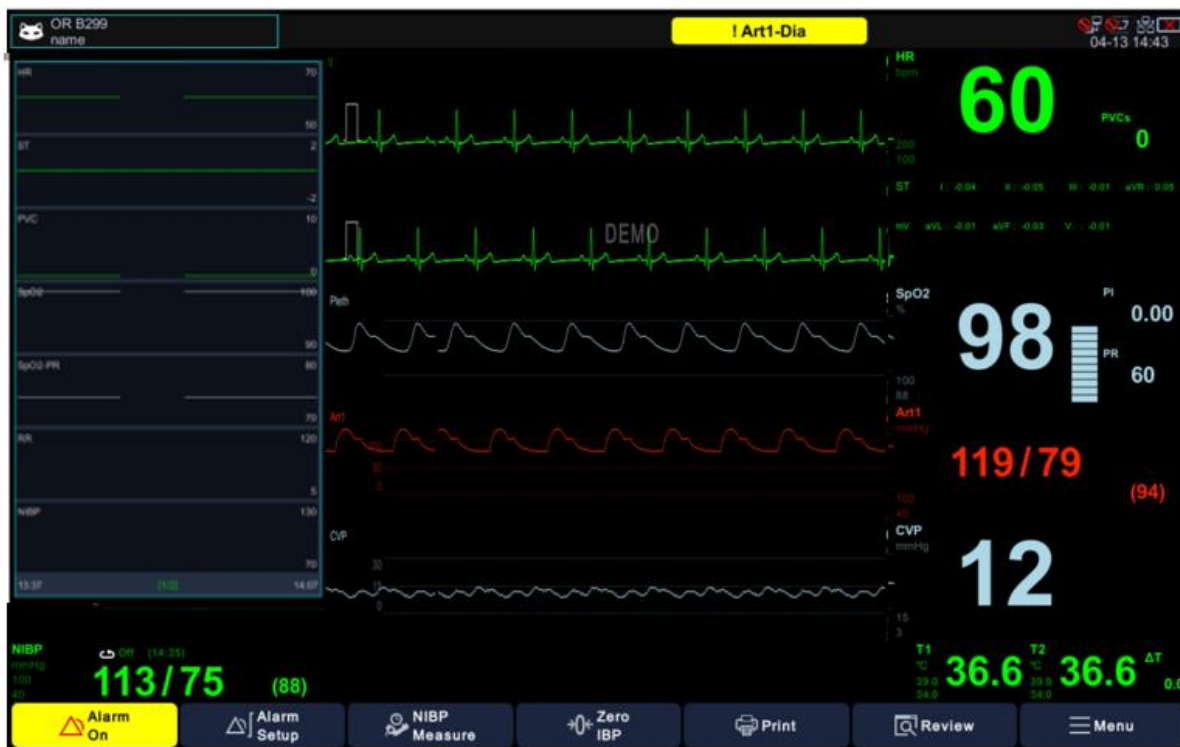

You can continue to monitor the main screen waveform and parameter box while watching the trend data for up to 7 parameters for up to 6 hours. The pop-up trend graph follows the display order indicated by each parameter in the trend setup and is updated with new trend data every 60 seconds.

To change the popup menu window, touch the top and bottom of the popup menu with the touch key, or select it with the rotary switch. You can change the size of the popup menu by pressing and releasing the center of the popup menu for at least 0.5 second.

## 7) Troubleshooting

This section lists the problems that might occur. If you encounter the problems when using the monitor or accessories, check the table below before requesting service. If the problem persists, contact your service representative.

---

Problem	Solution
When the data is unable to be saved	The trend data may not have been saved. No trend data is saved when the patient is <i>discharged</i> . Make sure the patient is admitted.

## PART 7. ECG

### 1) Overview

The monitor can calculate heart rate, detect arrhythmias and display ECG data.

The electrocardiogram screen provides 1 channel, 2 channel and 7 channel displays.

The monitor's Analysis System is intended to acquire, analyze, display, and record electrocardiographic information from animals(Horses, Dogs, and Cats).

The Brio XVET series is intended to be used by personnel trained in hospitals or medical professional facilities under the direct supervision of a licensed healthcare practitioner.

### 2) ECG Precautions

#### Warning

- For defibrillator protection, use only accessories specified by the manufacturer, such as electrodes, leads, and patient cables.  
  
Follow the instructions for use and adhere to all warnings and cautions.
- CABLES — Keep all cables away from patient's throat to avoid possible strangulation.
- CONDUCTIVE CONNECTIONS — Extreme care must be exercised when applying medical electrical equipment. Many parts of the human/machine circuit are conductive, such as the patient, connectors, electrodes, transducers. It is very important that these conductive parts do not come into contact with other grounded, conductive parts when connected to the isolated patient input of the device. Such contact would bridge the patient's isolation and cancel the protection provided by the isolated input. There must be no contact of the neutral electrode and ground.
- DEFIBRILLATION — Do not make contact with patient during defibrillation. Otherwise, severe injury or death could result.  
  
To avoid the risk of serious electrical burn, shock, or other injury during defibrillation, all persons must keep clear of the bed and must not touch the patient, or any devices connected to the patient.

After defibrillation, the screen display recovers within 5 seconds if the correct electrodes are used and applied in accordance with the manufacturer's instructions. Patient cables can be damaged when connected to a patient during defibrillation. Check cables for functionality before using them again.

The peak of the synchronized defibrillator discharge should be delivered within 60ms of the peak of the R wave. The signal at the ECG output on the veterinary multiparameter monitor is delayed by a maximum of 30ms.

- If the ECG waveform on the screen is too unstable to synchronize with the patient's heartbeat because of the following reason, remove the cause of an alarm, message, or unstable ECG, and then use a stable ECG lead for synchronization.
  - ✓ ECG electrode is detached, or broken Lead wire is detached or broken.
  - ✓ Lead wire moves, AC interference, EMG noise or noise from ESU is superimposed.
  - ✓ Connection cable is broken or has a short circuit Connector has poor contact.
- **INTERFACING OTHER DEVICES** — Devices may only be interconnected with each other or to parts of the system when a qualified biomedical engineering personnel determined that there are no dangers to the patient, the operator, or the environment as a result. In the instances when there are any element of doubt concerning the safety of connected devices, you must contact the manufacturers regarding the concerned matters (or other informed experts) for proper use. In all cases, safe and proper operation should be verified with the applicable manufacturer's instructions for use and system standards. IEC 60601-1-1/EN 60601-1-1 must be complied with.
- **Electro Surgery Unit**
  - ✓ Electrosurgical unit (ESU) emits a lot of RF interference. If the veterinary

multiparameter monitor is used with an ESU, RF interference may affect the monitor operation.

- ✓ Locate the veterinary multiparameter monitor as far as possible from the ESU. Locate them on opposite sides of the operating table, if possible.
- ✓ Connect the veterinary multiparameter monitor and ESU to different AC outlets located as far as possible from each other.
- ✓ When using the veterinary multiparameter monitor with an electrosurgical unit, its return plate and the electrodes for monitoring must be firmly attached to the patient. If the return plate is not attached correctly, it may burn the patient's skin where the electrodes are attached.

- **During Surgery:**

Use the appropriate orange electrode ECG safety cable, or lead cable with a red connector, to measure ECG in the operating room. These cables have extra circuitry to protect the patient from burns during cautery, and they decrease electrical interference. This also reduces the hazard of burns in case of a defective neutral electrode at the HF device. These cables cannot be used for measuring respiration.

- Vibrations during intrahospital transport may disturb ECG measurement.

**Caution**

- The veterinary multiparameter monitor is not intended for direct cardiac application.
- Ensure that the conductive parts of ECG electrodes and associated connectors, including the neutral electrode, do not come into contact with any other conductive parts including earth.
- To minimize the hazard of burns during high-frequency surgical procedures, ensure that the veterinary multiparameter monitor's cables and transducers never come into contact with the electrosurgery unit (ESU).

- **To minimize the hazard of burns during use of high-frequency surgical unit (ESU), the ECG electrodes should not be located between the surgical site and the ESU return electrode.**

### 3) Preparing the Patient

Proper skin preparation is necessary to ensure good signal quality at the electrode sites, as the skin is a poor conductor of electricity. To properly prepare the skin, choose flat areas and then follow this procedure:

- Shave hair from skin at chosen electrode sites.
- Gently rub skin surface at sites to remove dead skin cells.
- Thoroughly cleanse the site with a mild soap and water solution. (We do not recommend using ether or pure alcohol because this dries the skin and increases the resistance.)
- Dry the skin completely before applying electrodes.

In the event of a technical alarm such as a broken lead, re-prepare the patient according to the recommendations above.

## 4) Connector and Measuring Cable

ECG connector



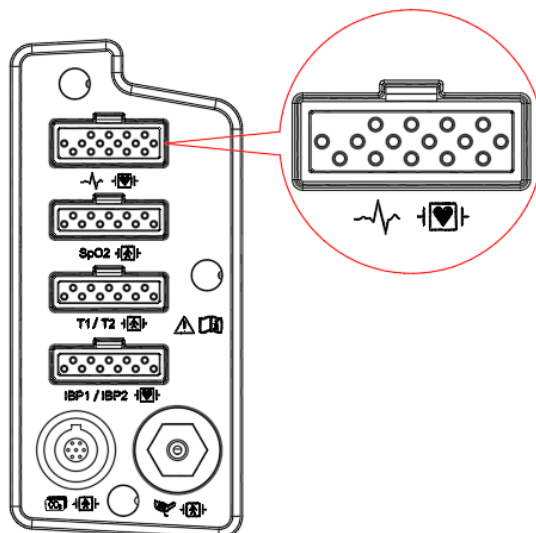

Brio X3VET

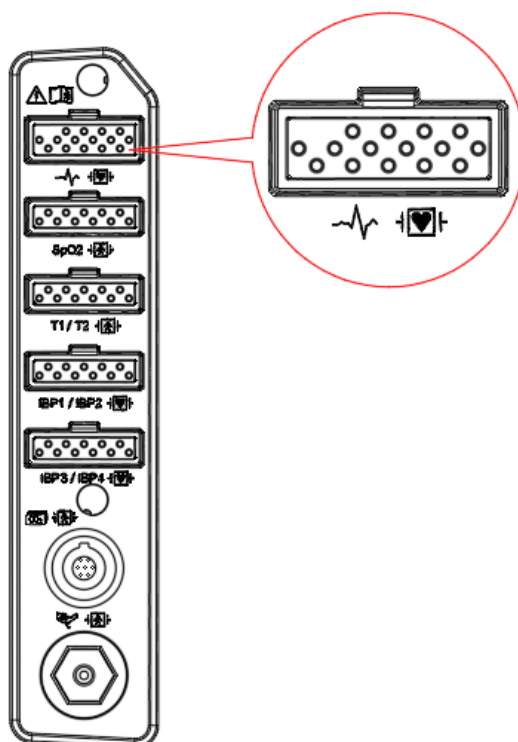

Brio X5VET , Brio X7VET



## ECG Measuring Cable

Number	Part	Picture	Dimension	Weight
1	ECG Cable (152600-041200)		MECA 3 LEAD CABLE main : $2500\pm 30\text{mm}$ lead : $1000\pm 20\text{mm}$	169g
2	ECG Cable (152600-041400)		MECA 3 LEAD CABLE main: $2500\pm 30\text{mm}$ lead: $1000\pm 20\text{mm}$	169g
3	ECG Cable (152600-041600)		MECA 5 LEAD CABLE main: $2500\pm 30\text{mm}$ lead: $1000\pm 20\text{mm}$	203g
4	ECG Cable (152600-041800)		MECA 5 LEAD CABLE main: $2500\pm 30\text{mm}$ lead: $1000\pm 20\text{mm}$	203g

5	ECG Extension Cable (152600-047100)		3-Lead ECG Extension Cable, AHA : $2500 \pm 30$ mm	163g
6	ECG Extension Cable (152600-047200)		5-Lead ECG Extension Cable, AHA : $2500 \pm 30$ mm	155g
7	ECG Cable (152600-002100)		3 lead ECG cable (alligator type) $1000 \pm 20$ mm	55g
8	ECG Cable (152600-002800)		5 lead ECG cable (alligator type) $1000 \pm 20$ mm)	60g
9	ECG Cable (130336-001020)		Esophageal probe with 3-lead ECG and temperature, extra small size $4550 \pm 100$ mm	152g
10	ECG Cable (130336-001000)		Esophageal probe with 3-lead ECG and temperature, medium size $4550 \pm 100$ mm	152g

## 5) Attaching Electrodes

1. Unpack the electrode package and take out the electrodes.
2. Remove the protecting film on surface of the electrode. Be careful not to touch the adhesive side.
3. Attach the disposable electrodes to the sterilized skin, which has been prepared as mentioned earlier.
4. Connect the lead of the electrodes to the monitor cable.
5. Fix the electrodes to the skin and secure the cable with the remaining length between the monitor and the electrode by using surgical tape. This fixation prevents the electrode from moving.

Change the electrodes every 24 to 48 hours to improve signal quality. You may need to replace them more often in the following situations:

- ECG signal degradation
- Excessive sweating of the patient
- Patient's skin irritation

There are a variety of reusable and disposable electrodes available. Choose the electrodes that best fits for monitoring situation. Bionet recommends Ag / AgCl disposable electrodes.

If you are using a gel before attaching the electrodes, make sure that the gel is applied sufficiently on the electrodes. Never use disposable electrodes that have passed their expiration date or if the gel has dried.

Determine the electrode locations that provide the best ECG in the configuration (P-wave and T-wave amplitudes should not exceed 1/3 of the QRS amplitude).

Choose a flat, less muscular location to maximize contact with the electrodes and minimize muscle fatigue. Avoid joints or bony protrusions.

When choosing a location for electrode placement, consider the following special conditions:

- Surgery patient - Place electrodes as far away as possible from the surgical area.
- Burn patient - Use sterile electrodes. Clean the monitor thoroughly. Follow the procedures of infection control from the hospital.

**Note**

- **Make sure that the contact area of the disposable electrode are not dry to maintain good connection between the electrode and the skin.**
- **If you suspect that the disposable electrode is in poor contact, replace it immediately with a new one. Otherwise, the contacting impedance of the skin and electrode is increased, and the ECG signal is not obtained correctly.**
- **If the packing condition is not proper even if the expiration date on the packaging is not reached yet, it should be replaced with a new one.**
- **To get a stable ECG waveform, rub the skin with gel or benzoin tincture.**

**Caution**

- **When using a generating electric potential equipment, it may interfere with ECG monitoring.**
- **Do not rely solely on ECG for patients with epileptic tendencies. Electrical disturbances of non-cardiac circles such as seizures may interfere with the detection of specific arrhythmias.**

## 6) ECG Lead

### 5-Lead Electrode Placement

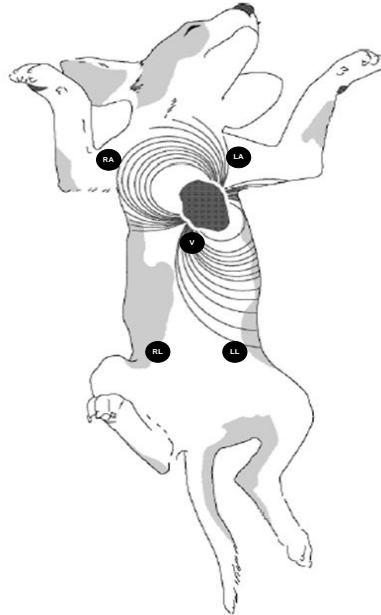

### 3-Lead Electrode Placement

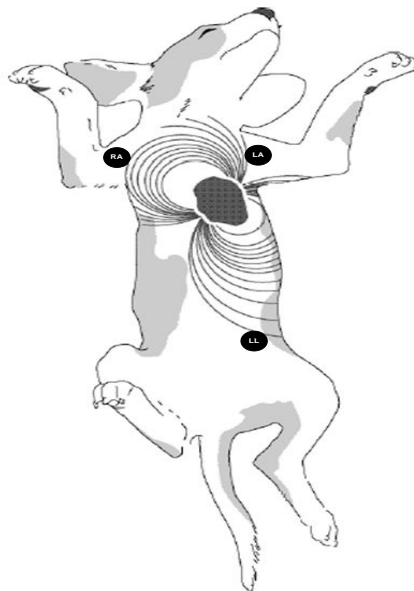

## Cable Color and Size

AHA: American Heart Association (U.S.A. standard)

IEC: International Electro technical Commission (Europe standard)

3-Lead / 5-Lead

Lead wire	AHA Color code	AHA Label	IEC Color code	IEC Label
Right arm	White	RA	Red	R
Left arm	Black	LA	Yellow	L
Right leg	Green	RL	Black	N
Left leg	Red	LL	Green	F
V1 (precordial)	Brown	V	White	C

## 7) ECG Signal Processing and Display

The monitor distinguishes the QRS amplitude of 0.4 to 5.0 mV (0.2-5.0 mV with a scale setting of 0.5 mV / cm or less) and an large animal with a QRS width of 70-120ms (or small animals with a QRS / ARR Select chapter). The heart rate is calculated from 15 to 300 times per minute using the last 10 seconds of the R-R interval and the two longest intervals and the two shortest intervals at the R-R interval. The remaining interval is averaged, and the current heart rate is displayed in the HR parameter area of the main screen as a result.

When using arrhythmia monitoring, when an arrhythmia alarm occurs, the name of the arrhythmia is displayed in the upper right corner of the ECG waveform area and in the vital signal alarm message area of the screen. (Refer to 8. Monitoring Arrhythmia for details on arrhythmia monitoring for details on arrhythmia monitoring.)

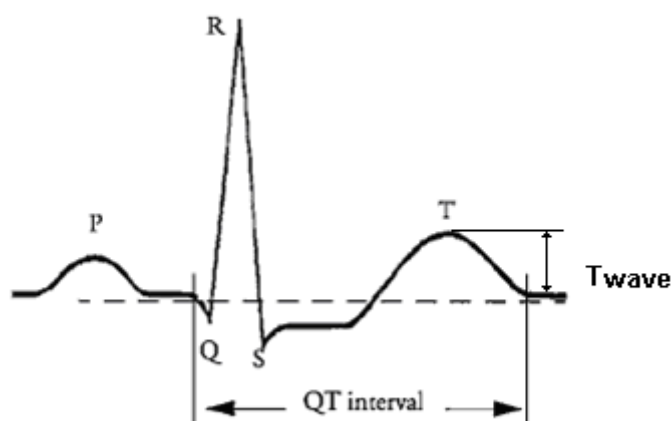

When the ECG signal is 80 BPM, the interval of the T wave is 180ms, and the QT period is 350ms.

## 8) ST Signal Processing and Display

ST segment deviation is defined as movement above or below the equipotential level (mm). The difference is compared at the equipotential and ST measurement points. The isoelectric point defines the 0V point (no electrical activity, 0mm) on the horizontal axis (time) whose default position is at the F-Point (R peak) position before the ISO time setting time occurs. The ST point in the ST segment is the value of the ST time set-up time at the F-point (R peak).

The ST analysis feature examines the QRS complex that are classified as "normal" beats, from the selected ECG leads. The monitor learns each ST-lead and combines measurements and characteristics of a normal beat into a composite (or average) QRS Complex. Take the ST segment deviation from this mean. If ST monitoring is enabled, the current ST value is stored in the trend and can be reviewed in the trend display. The significance of the ST segment changes needs to be determined by a clinician.

## 9) Alarm and Its Status

High P-wave and T-wave - Long P-wave or T-wave with high amplitude duration can be detected by QRS Complex. Place the leads on the ECG1 channel with the highest R-wave (compare to T-wave and / or P-wave) to allow the monitor to detect properly low heart rate conditions in this situation. If the monitor continues to misinterpret the P-wave or T-wave, use a pulse oximeter to reposition the electrodes or monitor the patient's pulse rate.

## 10) Display



- ① Heart rate: Displays the heart rate per minute.
- ② HR Alarm limits: Displays heart rate threshold.
- ③ PVC count number per 1 minute
- ④ ST value per channel

## 11) Setting ECG

When you select an ECG value or waveform area, the setup menu appears.

Menu	Description	Available settings
<b>A. Alarm</b>	ECG alarm setting menu	HR, ST, PVCs
<b>A-1. Alarm</b>	Set whether to detect an alarm.	On, Off
<b>A-2. Priority</b>	Set alarm priority.	High, Medium, Low
<b>A-3. Low / High</b>	Set alarm low/high limit value.	
<b>A-4. Print</b>	Set print when an alarm occurs.	
<b>B. Setup</b>	ECG settings	
<b>B-1. Speed</b>	Set wave sweep speed.	6.25mm/s, 12.5mm/s, 25mm/s, 50mm/s
<b>B-2. Size</b>	Set wave size.	x0.25, x0.5, x1, x2, x4
<b>B-3. Filter</b>	Set waveform filter.	Diagnostic, Monitor, Surgery, ST
<b>B-4. View channel</b>	The number of channels of the ECG waveform to be displayed on the screen  Menu is displayed according to the currently connected cable.  The ECG waveform of 1CH is displayed in two lines.	Common: 1CH, 5-Lead : 2CH, 7CH
<b>B-5. View channel Trace 1, Trace 2</b>	Select ECG Channel.  Menu is displayed according to the currently connected cable.  Trace2 is displayed when View Channel	*3-Lead : I / II / III *5-Lead : I / II/ III/ aVR/ aVL/ aVF/ V

	is 2CH.	
<b>B-6. QRS Volume</b>	Set QRS volume. When SpO2 pulse rate volume is turned on, QRS volume is automatically turned off.	Off ~100% (10% unit)
<b>B-7. HR source</b>	Select heart rate source. When it is set to Auto, if ECG cable is not connected, SpO2 pulse is displayed.	ECG, SpO2, Auto
<b>C. ST/PVC</b>	PVC and ST analysis setup	
<b>C-1. PVC analysis</b>	Set PVC analysis result display. When it is set to On, PVCs are displayed.	On, Off
<b>C-2. ST analysis</b>	Set ST analysis result display. When it is set to On, ST value for each channel is displayed.	On, Off
<b>C-3. ST Template</b>	ST Template wave form It is updated periodically (1 second).	
<b>C-4. ST template &gt; Channel</b>	Set ST analysis ECG channel. Menu is displayed according to the currently connected cable.	*3-Lead: I / II / III *5-Lead: I / II/ III/ aVR/ aVL/ aVF/ V
<b>C-5. ST Template &gt; Initial setup</b>	Set ISO, ST point position initial value.	ISO: 90 ms ST: 60 ms
<b>C-6. ST Template &gt; ISO(R-)</b>	Set ISO point position. It can be increased or decreased in 2ms increments.	20~160 ms
<b>C-7. ST Template &gt; ST(R+)</b>	Set ST point position. It can be increased or decreased in 2ms increments.	20~160 ms

## 12) Full Disclosure Review



Enable to check the ECG waveform on the Full disclosure screen in the Review menu. Full disclosure data can be stored for up to 48 hours, and the old data is deleted when the storage exceeds its capacity.

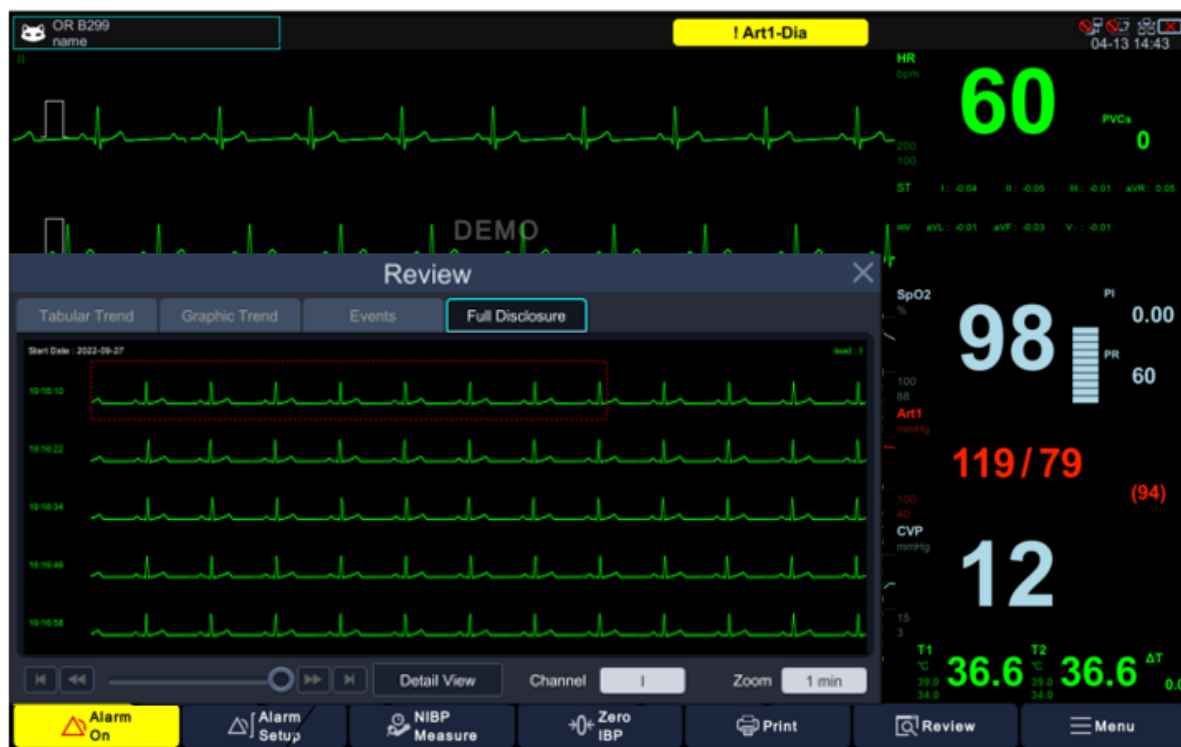

Menu	Description	Available settings
<b>A. Full disclosure</b>	View ECG Waveforms.	
<b>A-1. Disclosure View</b>	Display the ECG waveform in 5 rows according to the zoom setting. Tab the view area to move the cursor to that position.	
<b>A-2. Page move and navigation slider</b>	Move Section and update data.	
<b>A-3. Channel</b>	Select ECG channel. When it is changed, the waveform is updated with the selected channel.	I / II/ III/ aVR/ aVL/ aVF/ V
<b>A-4. Zoom</b>	View resolution settings.	1 min, 2 min, 3 min, 4 min, 5 min
<b>B. Detail</b>	Cursor Area Details	
<b>B-1. View</b>	Display with set waveform layout	
<b>B-2. Waveform</b>	Set Waveform layout.	7 ch, 3ch + 1
<b>B-3. Rhythm Channels</b>	Set Rhythm Channel.	I / II/ III/ aVR/ aVL/ aVF/ V

### 13) Troubleshooting

This section lists the problems that might occur. If you encounter some problems when using the monitor or accessories, check the table below before requesting service representative. If the problem persists, please contact your service representative.

Problem	Solution
Noisy ECG traces	<ol style="list-style-type: none"> <li>1. Check that the electrodes are not detached or dry. Replace with new ones if necessary.</li> <li>2. Check that lead wires are not defective. Replace lead wires if necessary.</li> </ol> <p>Check that the patient cable or lead wires are not too close to other electrical devices. Move the patient cable or lead wires away from electrical devices if necessary.</p>
Muscle Noise	<p>Inadequate skin preparation, tremors, tense subject, and/or poor electrode placement.</p> <ol style="list-style-type: none"> <li>1. Perform skin preparation again and re-place the electrodes. For more information, refer to <b>Preparing the Patient and Attaching the Electrodes.</b></li> <li>2. Apply new with moist electrodes. Avoid muscular areas.</li> </ol>
Intermittent Signal	<ol style="list-style-type: none"> <li>1. Check that cables are properly connected.</li> <li>2. Check that electrodes are not detached or dry. Perform skin preparation again on patient and apply new with moist electrodes.</li> <li>3. Check that the patient cable or lead wires are not damaged. Change them if necessary.</li> </ol>
Excessive alarms: heart rate, lead fault	<ol style="list-style-type: none"> <li>1. Check that electrodes are not dry. Perform skin preparation again and re-place the electrodes. For more information, see Preparing the Patient and Attaching Electrodes.</li> <li>2. Check for excessive movement of patient or muscle tremor. Reposition the electrodes. Replace new with moist electrodes if necessary.</li> </ol>
Low Amplitude ECG Signal	<ol style="list-style-type: none"> <li>1. Check if the ECG gain is set too low. Adjust the gain control as required. For more information, see ECG setup menu.</li> <li>2. Perform skin preparation again and re-place the electrodes. For more information, see Preparing the Patient and Attaching Electrodes.</li> </ol>

	<ol style="list-style-type: none"> <li>3. Check electrode application. Avoid bone or muscular area.</li> <li>4. Check that electrodes are not dry or have been used for a prolonged time. Replace with new ones if necessary.</li> </ol>
No ECG Waveform	<ol style="list-style-type: none"> <li>1. Check if the ECG gain is set too low. Adjust the gain control as required. For more information, see ECG Setup menu.</li> <li>2. Check if the lead wires and patient cables are properly connected.</li> <li>3. Change cable and lead wires if necessary.</li> <li>4. Check that the patient cable or lead wires are not damaged. Change them if necessary.</li> </ol>
Base Line Wander	<ol style="list-style-type: none"> <li>1. Check for excessive movement of patient or muscle tremor. Secure lead wires and cable.</li> <li>2. Check that electrodes are not detached or dry and replace with new ones if necessary. For more information, see Preparing the Patient and Attaching Electrodes.</li> <li>3. Check ECG filter setting.</li> </ol>

## PART 8. Monitoring Arrhythmia

### 1) Overview

The monitor compares the received beats to the reference beats that have been recorded and stored in the reference template. Through this process, it can identify the occurrence of an arrhythmia event, classify it, and draw clinical conclusions based on the frequency and type of the signal. It observes all doubtful beats if the baseline moves beyond a defined limit. It uses QRS processing results for arrhythmia analysis. During multiple lead arrhythmia treatment, it measures the QRS Complex of each lead and compare it to the main learned beats. It classifies the beats based on information obtained from all available leads.

When an arrhythmia alarm occurs, the message below is displayed in the upper right corner of the ECG waveform area and in the bio signal alarm message area on the screen.

### 2) Arrhythmia Template

Template	Description	
<b>Asystole</b>	Ventricular asystole occurs whenever the displayed heart rate drops to zero.	
<b>V-Fib / V-Tach</b>	Ventricular fibrillation occurs when the ECG waveform indicates a chaotic ventricular arrhythmia.	
<b>V-Tach</b>	Large animal	Occurs when three or more ventricular beats greater than 100 beats per minute are detected.
	Small animal	Occurs when three or more ventricular beats greater than 150 beats per minute are detected.
<b>Acc Vent</b>	Large animal	Accelerated ventricular occurs when six or more ventricular beats are detected with an average heart rate for the ventricular beat between 50 and 100 beats per minute.
	Small animal	Occurs when six or more ventricular beats are detected with an average heart rate for the ventricular beat between 60 and 160 beats per minute.
<b>Bigeminy</b>	Occurs when two or more bigeminal cycles (a ventricular beat followed by a non-ventricular beat) are detected.	

<b>Couplet</b>	Occurs when two ventricular beats are detected and have non-ventricular beats before and after the couplet. The coupling interval must be less than 600 milliseconds.	
<b>Irregular</b>	Occurs when six consecutive normal R-to-R intervals vary by 100 milliseconds or more.	
<b>Pause</b>	Occurs when the interval between two consecutive beats exceeds three seconds.	
<b>PVC</b>	Isolated premature ventricular complexes occur when a premature ventricular beat is detected and has non-ventricular beats before and after.	
<b>R on T</b>	Occurs when ventricular COMPLEX is detected within the repolarization period of the normal beat (when the RR interval is less than or equal to 360 msec)..	
<b>Trigeminy</b>	Occurs when two or more trigeminal cycles (a ventricular beat followed by two non-Ventricular beats) are detected.	
<b>Short Run</b>	Occurs when three or more consecutive ventricular beats are detected and have a normal beat before/after.	
<b>V-Brady</b>	Large animal	Occurs when three or more ventricular beats less than 50 beats per minute are detected.
	Small animal	Occurs when three or more ventricular beats less than 60 beats per minute are detected.

**Note**

- **The Brady limit matches the low heart rate limit. If the low heart rate limit is changed, the Brady limit changes.**
- **The Tachy limit matches the high heart rate limit. If the high heart rate limit is changed, the Tachy limit changes.**

### 3) Setting Arrhythmia

When you select an ECG value or waveform area, the setup menu appears. Select the Arrhythmia tab.

Menu	Description	Available settings
<b>1. Arrhythmia List</b>	List of arrhythmias	Asystole, V-Tach, V-Tach/V-Fib, Bigeminy, Trigeminy, Acc Vent,

		Couplet, Irregular, Pause, R on T, V-Brady, Short Run, PVC
<b>2. Alarm</b>	Set whether to detect an alarm.	On, Off
<b>3. Priority</b>	Set alarm priority.	High, Medium, Low
<b>4. Print</b>	Set print when an alarm occurs.	On, Off
<b>5. Off</b>	Turn off all arrhythmia alarms.	
<b>6. Lethal</b>	Turn on Asystole, V-Tach, V-Tach/V-Fib alarms only.	
<b>7. Full</b>	Turn on all arrhythmia alarms.	

**Warning**

- **VENTRICULAR ARRHYTHMISAS**

The arrhythmia analysis program is intended to detect ventricular arrhythmia. This program is not designed to detect trial or supra ventricular arrhythmias. In some cases, it may not be possible to distinguish the presence or absence of arrhythmias. Therefore, doctors should analyze the arrhythmia information like other medical information.

- **SUSPENDED ANALYSIS**

Certain conditions can delay the arrhythmia analysis. Detection and alarms associated with arrhythmias do not occur when arrhythmia conditions are delayed. This message is generated when the arrhythmia analysis is delayed:

- **Lead Fault, Alarm Paused, Alarm Off, Patient Discharge**

---

## PART 9. RESPIRATION

### 1) Overview

Respiration via ECG Lead I or Lead II electrode is measured by using the changes in the resistance of skin, caused by the chest skin enlargement. In this process, the respiration value per minutes is calculated and the alarm is triggered according to limit value.

The monitor can use ECG leads I or II for breath detection, regardless of the leads selected for QRS processing.

### 2) RESP Precautions

The safety and effectiveness of respiration measurement methods in detecting apnea have not yet been established.

- The veterinary multiparameter monitor does not monitor obstructive apnea. Patients in a breathing crisis should be closely monitored.
- Impedance breath monitoring should not be considered as the only way to detect breathing stops. Bionet recommends monitoring of additional parameters, such as EtCO<sub>2</sub> and SpO<sub>2</sub>, that indicate the patient's oxygen supply status.
- If you use an ESU block or cable, the impedance breath monitor may not work, and the pacemaker detection performance may be degraded. If pacemaker detection is enabled, ESU interference may be detected as a pacemaker.
- Large amplitude pacemaker pulses ( >100mV ) may interfere with the monitor's breath measurement or detection function.

### 3) Preparing the Patient

Skin preparation and electrode placement must be properly and carefully monitored in impedance breath monitoring. Refer to the **Preparing the Patient in PART 7**.

In general, the electrodes should be placed as clean as possible with the 60Hz noise minimized to make it possible to generate a signal. The best results can be obtained when the electrodes are firmly bonded, and the electrode area is wide.

To improve the RESP signal, use a 5-lead cable set (RL as a neutral electrode). It is recommended that the electrodes be placed in the maximum expansion and contraction range of the lung, especially if deep breathing is involved.

**Note**

**Cables and connectors to measure respiration rate (RR) are commonly used with ECG.**

#### 4) Display



- ① The number of respirations per minute
- ② Respiration alarm limit indicates respiration limits

## 5) Respiration Setting Menu

When you select the numerical or waveform area of Resp, the setting menu appears.

Menu	Description	Available settings
<b>A. Alarm</b>	Set RESP alarm.	RR, Zero RR
<b>A-1. Alarm</b>	Set whether to detect an alarm.	On, Off
<b>A-2. Priority</b>	Set alarm priority.	High, Medium, Low
<b>A-3. Low / High</b>	Set Alarm low/high limit value.	
<b>A-4. Print</b>	Set print when an alarm occurs.	
<b>B. Setup</b>	Setup menu	
<b>B-1. Speed</b>	Set Waveform range speed.	6.25 mm/sec 12.5 mm/sec 25.0 mm/sec
<b>B-2. Size</b>	A menu to setup wave display	x2, x4, x6, x8, x10
<b>B-3. Lead selection</b>	This is for changing the reference lead for respiration.	Lead I Lead II

## PART 10. SpO2

### 1) Overview

SpO2 monitoring is a non-invasive technique that measures the total amount of oxygen in hemoglobin. The pulse rate is measured by measuring the absorption of the wavelength of the selected light. The light emitted by the sensor in the probe passes through the tissue and is converted into an electrical signal by the light-detecting sensor in the probe. The monitor processes the electrical signal and displays the waveform, %SpO2, and pulse rate on the screen as quantified values.

Red light and infrared light passed through capillaries at the tip of the tongue to detect pulsation components, calculate HR and oxygen saturation, and alarm according to the set alarm value. You can calibrate the patient monitor to display functional oxygen saturation.

### 2) Precautions

SpO2 measurements are particularly sensitive to arterial and arteriolar pulse rates. Patients experiencing shock, hypothermia, anemia, or patients taking medications that reduce arterial blood flow may have incorrect measurements.

#### Warning

- **The pulse oximeter cannot be used as an apnea monitor.**
- **Ambient lighting, physical behavior, diagnostic tests, electromagnetic interference, and improper positioning of the probe may affect SpO2 accuracy.**
- **Sensor may be used on the same site for a maximum of 10 minutes provided the site is inspected routinely to ensure skin integrity and correct positioning. Because individual skin condition affects the ability of the skin to tolerate sensor placement, it may be necessary to change the sensor site more frequently with some patients.**
- **Check compatibility before using the veterinary multiparameter monitor,**

probe, and cable specified by the Bionet.

- Use only Bionet-designated sensors. Other sensors may not provide adequate protection against defibrillation or may put the patient at risk.
- Disposable accessories (disposable electrodes, transducers, etc.) should be used only once. Do not reuse disposable accessories.
- When the monitor is connected to electrosurgical units, make sure the sensor and cables do not make contact with the electrosurgical unit. The patient lead and conducting wire must be far away from the operating table and other devices. The electrosurgical unit should be properly grounded.
- When the monitor is connected to high frequency electrosurgical equipment, do not allow the sensor from the monitor to come into contact with the high frequency electrosurgical equipment or its cables. Otherwise, electric leakage may occur and may cause burns to the patient.
- Pulse oximeters have been validated for low perfusion accuracy in bench-top tests on simulators with signal strength of 0.02% or more, and transmissions of 5% or more to standard deviations include 68% of the population.

### 3) Preparing the Patient

The accuracy of SpO<sub>2</sub> monitoring is largely dependent on the strength and quality of the SpO<sub>2</sub> signal.

Place the sensor on the tip of the animal's tongue as a monitoring site. Only use sensors provided by Bionet and apply them according to manufacturer's recommendations on a per-sensor basis.

If the sensor is not attached correctly, the ambient light may interfere with the pulse oximetry, making the measurement irregular or causing the value to disappear. If you suspect interference from ambient light, make sure that the sensor is properly positioned and that the sensor cover with the opaque body is covered.

1. Select the sensor type and size that best suits your patient.
2. If the sensor can be reused, please wash it before use for each patient.

3. Position the sensor correctly and attach it to the patient.
4. Connect the sensor to the patient cable.
5. Check the application area of the sensor from time to time. If the sensor is too tight, it may delay blood flow or overheat the skin and damage the tissue. Do not use a damaged sensor.

**Note**

- Read the documentation that came with your sensor for the best application technology and safety information. Never use a damaged sensor.
- If the sensor does not turn on after connecting the sensor, observe that a message appears on the veterinary multiparameter monitor. If the sensor-LED does not turn on, replace the sensor.

## 4) Connector and Measurement Cable

SpO2 connector

Brio X3VET

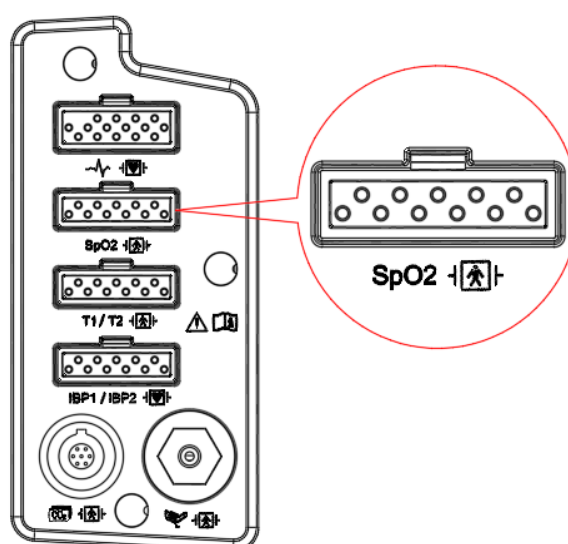

**Brio X5VET , Brio X7VET**

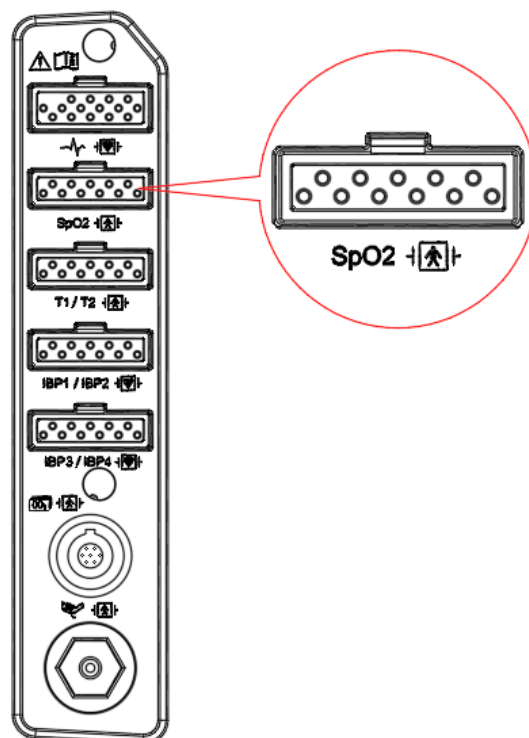

**SpO2 measurement extension cable**

Number	Part	Picture	Dimension	Weight
1	152600-042700		SPO2 EXTENSION CABLE 2000±50mm	120g

## SpO2 sensors

Number	Part	Picture	Dimension	Weight
1	SpO2 probe (152600-032400)	A coiled white cable with a clear plastic sensor tip at the end.	Transflectance SpO2 probe for veterinary  1000 ± 50 mm	100g
2	SpO2 probe (152600-032410)	A coiled white cable with a clear plastic sensor tip at the end.	Transflectance SpO2 probe for veterinary  3000 ± 50 mm	300g
3	SpO2 probe (152600-003331)	A white cable with a Y-shaped connector at the end.	SpO2 multi-site Y sensor  1500 ± 50 mm	100g
4	SpO2 probe, (SREUP-A103, 152600-003300)	A yellow cable with a clear plastic sensor tip at the end.	SPO2 Probe  1000 ± 50 mm	100g

**Note**

The signal input is a high-insulation port protected from defibrillator. (  )  
The insulated input ensures patient safety and protects the veterinary multiparameter monitor during defibrillation and electro surgery.

## 5) Display

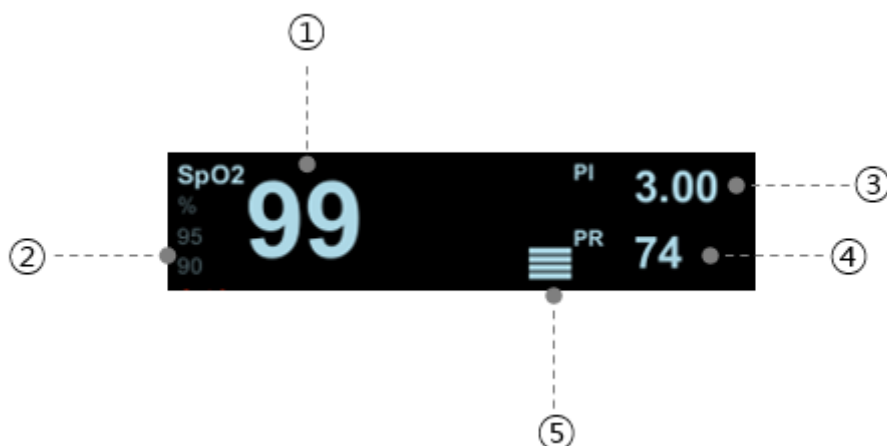

- ① %SpO2 Value display
- ② %SpO2 alarm limits display
- ③ SpO2 PI (Perfusion Index) measurement display
- ④ SpO2 pulse rate display
- ⑤ SpO2 strength indicator

The SPO2 measurements are averaged over a 6-second period of time and the monitor display is updated every second.

### Note

- **SpO2 wave size is changed automatically.**
- **A functional tester or SpO2 simulator (Fluke, Index 2 simulator) can be used to verify operation of pulse oximetry function.**
- **A functional tester or SpO2 simulator cannot be used to assess the SpO2 accuracy.**

## 6) Signal and Data Validity

It is extremely important to determine that the probe is attached to the patient correctly and the data is verifiable. To make this determination, three indications from the monitor are assisted: the signal strength bar, the quality of the SPO2 waveform, and the stability of the SPO2 values. It is critical to observe all three indications simultaneously when ascertaining signal and data validity.

### Signal Strength Bar

Pulse histogram and perfusion index (PI) are useful features that can be used to determine the reliability of readings. If the pulse bar's height is less than 30%, this indicates an inadequate signal and the displayed SpO2 or pulse rate values may be potentially inaccurate.

### Quality of SPO2 Waveform

Under normal conditions, the SPO2 waveform corresponds to (but is not proportional to) the arterial pressure waveform. The typical SPO2 waveform indicates not only a good waveform, but helps you find a probe placement with the least noise spikes present. The figure below represents an SPO2 waveform of good quality.

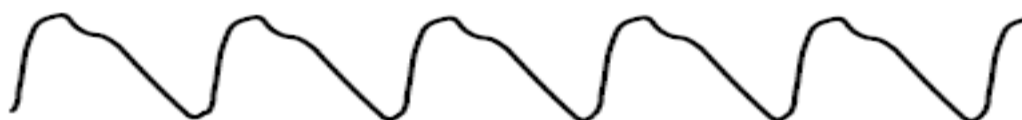

SpO2 Waveform in Good Quality

If noise (artifact) is seen on the waveform because of poor probe placement, the photo detector may not go through the tissue. Check that the probe is secured, and the tissue sample is not too thick. Pulse rate is determined from the SPO2 waveform which can be disrupted by a cough or other hemodynamic pressure disturbances. Motion at the probe site is indicated by noise spikes in the normal waveform (See the figure below). In order to reduce motion noise, you should carefully look at the SpO2 waveform and check the probe position on the patient.



SpO2 Waveform with Artifact

### SpO2 Wavelength and Optical Output Power

BSpO2 Oximax pulse oximetry display functional saturation.

This information can be useful to medical staff performing photodynamic therapy.

- The BSpO2 pulse oximetry sensor contains an LED that emits red light at a wavelength of approximately 660 nm and infrared light at a wavelength of approximately 905.920 nm.

### Stability of SpO2 Values

The stability of the displayed SpO2 values can also be used as an indication of signal validity. You can improve the stability of SpO2 values with a little practice. SpO2 Messages are provided in the SpO2 values window to aid you in successful SpO2 monitoring.

#### Warning

**In the monitoring of patients, the coincidence of adverse conditions may lead to a disturbed signal going unnoticed. In this situation, artifacts may simulate a plausible parameter reading, so that the veterinary multiparameter monitor fails to sound an alarm. In order to ensure reliable veterinary multiparameter monitoring, the proper application of the probe and the signal quality must be checked at regular intervals.**

## 7) SpO2 Setting Menu

When you select the numerical or waveform area of SpO2, the setup menu appears.

Menu	Description	Available settings
<b>A. Alarm</b>	Set SpO2 alarm.	SpO2, PR
<b>A-1. Alarm</b>	Set whether to detect an alarm.	On, Off

<b>A-2. Priority</b>	Set alarm priority.	High, Medium, Low
<b>A-3. Low / High</b>	Set Alarm low/high limit value.	
<b>A-4. Print</b>	Set print when an alarm occurs.	
<b>B. Setup</b>	Setup menu	
<b>B-1. Speed</b>	Set waveform range speed.	6.25 mm/sec, 12.5 mm/sec, 25.0 mm/sec, 50.0 mm/sec
<b>B-2. Rate Volume</b>	Set pulse volume. When ECG volume is set, it is automatically set to Off.	Off ~100% (10% unit)

## 8) Troubleshooting

This section lists the problems that might occur. If you encounter the problems when using the monitor or accessories, check the table below before requesting service representative. If the problem persists, contact your service representative.

<b>Problem</b>	<b>Solution</b>
"---" is displayed in place of numeric.	<ol style="list-style-type: none"> <li>1. Make sure the SpO<sub>2</sub> cable is securely connected. If necessary, replace the SpO<sub>2</sub> cable.</li> <li>2. Connect the SpO<sub>2</sub> sensor if the alarm Probe Off appears.</li> <li>3. Check the PI value. If the PI value is too low, adjust the SpO<sub>2</sub> sensor, or apply the sensor with better perfusion.</li> <li>4. Move the sensor to a place with weaker ambient light, or cover the sensor to minimize the ambient light if the alarm Too Much Light appears.</li> </ol>
Low amplitude SpO <sub>2</sub> signal	<ol style="list-style-type: none"> <li>1. The SpO<sub>2</sub> sensor and NIBP cuff are placed on the same limb. Change the monitoring site if necessary.</li> <li>2. Check the PI value. If the PI value is too low Adjust the SpO<sub>2</sub> sensor or apply the sensor to a site with better perfusion.</li> </ol>
SpO <sub>2</sub> value is inaccurate.	<ol style="list-style-type: none"> <li>1. Check the patient's vital signs.</li> <li>2. Check for conditions that may cause inaccurate SpO<sub>2</sub> readings.</li> <li>3. Check the monitor, the SpO<sub>2</sub> module for proper functioning.</li> </ol>

## PART 11. NIBP

### 1) Overview

The monitor uses the oscillometric method for measuring Non-Invasive Blood Pressure (NIBP). NIBP measurement is based on the principle that pulsatile blood flow through an artery creates oscillations of the arterial wall. The oscillometric device uses a blood pressure cuff to sense these oscillations that appear as tiny pulsations in cuff pressure, and measure the amplitude of pressure changes in the occluding cuff as the cuff deflates from above systolic pressure. The amplitude suddenly increases as the pulse breaks through the occlusion in the artery. As the cuff pressure decreases further, the pulsations increase in amplitude, reach a maximum (which approximates to the mean pressure), and then diminish. The oscillometric method measures the mean pressure and determines the systolic and diastolic pressures.

If the pulse signal is weak due to patient movement, improper cuff positioning, or noise in the signal, deflate the cuff and try a second measurement. Refer to the status alarm message table for causes and solutions for weak pulse signals. Connect the cuff and monitor with a hose to measure contraction, dilatation, and mean blood pressure in large animal or small animal.

The monitor's NIBP system expands and contracts the Pneumatic Cuff wrapped around the patient's arm or leg to initiate blood pressure measurement alone based on a set interval or persistence lasting more than 5 minutes.

#### Note

- **The veterinary multiparameter monitor has been clinically investigated in accordance with the requirements of ISO 81060-2: 2013, and the blood pressure measurements taken with the veterinary multiparameter monitor are identical to those obtained by the intra-arterial method within the limits prescribed by the Association for Advancement of Medical Instrumentation, Electronic Automated Sphygmomanometers (AAMI/ANSI SP-10).**
- **You can perform NIBP measurement during electro-surgery and discharge of a defibrillator.**
- **NIBP performance may be affected by extreme temperature, humidity, and altitude. For environmental conditions, refer to PART 25. System**

## Specifications.

## 2) Connector and Cuff

## Brio X3VET

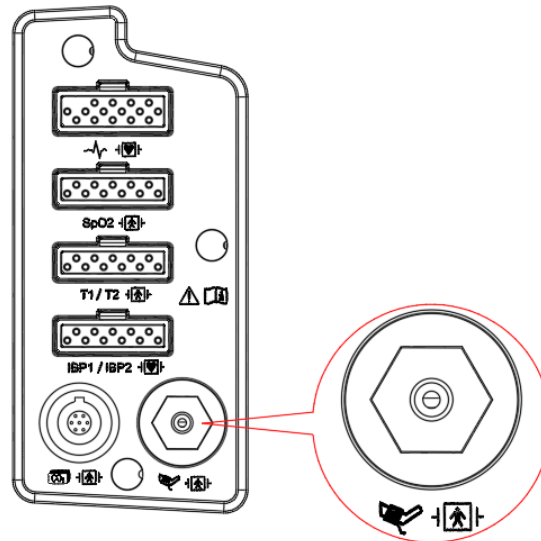

## Brio X5VET , Brio X7VET

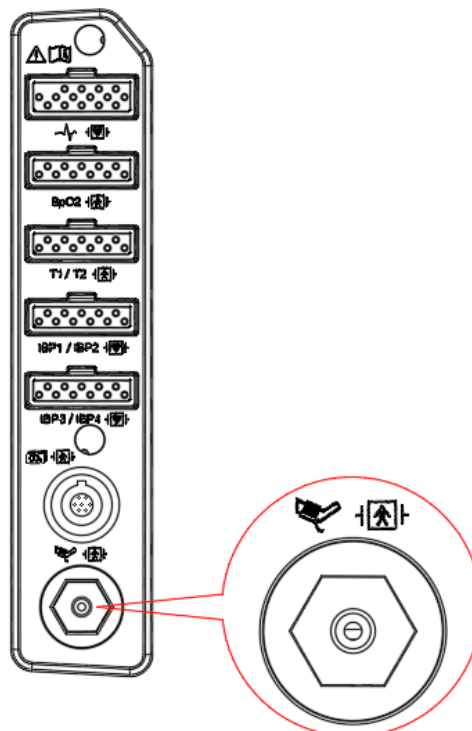

**Cuff extension tube**



**Optional accessory list**

<b>Cuff</b>		Using Scope 3-6cm
		Using Scope 4-8cm
		Using Scope 6-11cm
		Using Scope 7-13cm

		<p>Using Scope 8-15cm</p>
		<p>520 X 140mm</p>
		<p>212 X 57mm</p>
		<p>308 X 88mm</p>
		<p>405 X 112mm</p>
		<p>650 X 173mm</p>
		<p>812 X 210mm</p>

<p><b>Note</b></p>	<p>The ESU does not cause a burn hazard through the NIBP cuff, because there is no electrical connection between the cuff and the NIBP measuring electronics.</p>
--------------------	---

### 3) Position of cuff

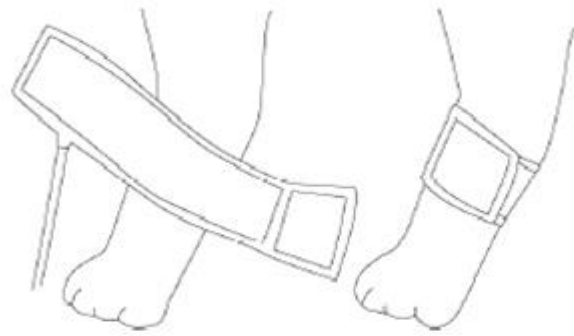

Incorrect Placement



Correct Placement

The hose should line up with the vessel that you are trying to measure. When using a leg, this is on the underside (backside) of the leg.

Note: The cuff must be at the same level as the patient's heart for best accuracy.

## 4) Display

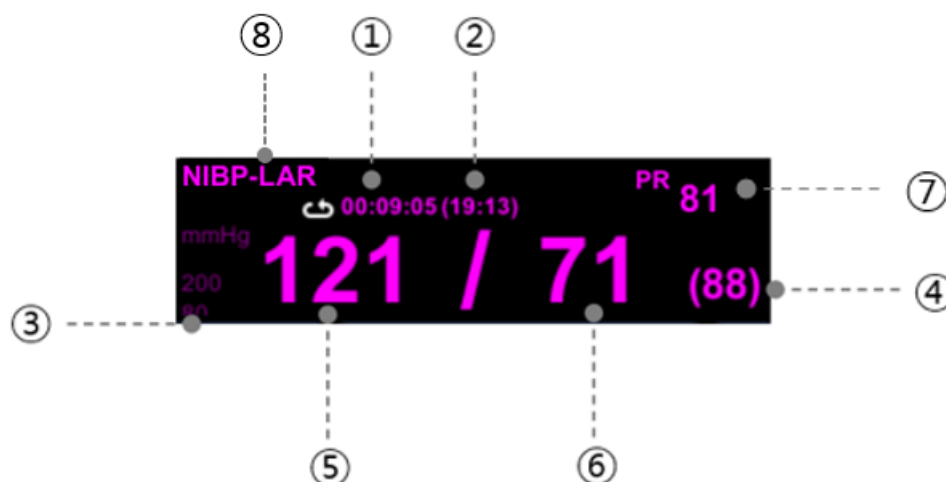

- ① Measurement period or remaining measurement time: Before measurement starts, the set measurement period is displayed. When the measurement is complete, the remaining time until the next measurement is displayed.
- ② Measurement completion time
- ③ Alarm upper/lower limits for systolic or diastolic blood pressure: When the systolic blood pressure alarm is off, the alarm upper/lower limits for diastolic blood pressure are displayed.
- ④ Mean blood pressure: Indicates the average blood pressure
- ⑤ Systolic blood pressure: Indicates the maximum blood pressure
- ⑥ Diastolic blood pressure: Indicates the minimum blood pressure
- ⑦ Pulse rates: Indicates pulse rate
- ⑧ Set cuff size

## 5) NIBP Setting Menu

When you select the NIBP numerical are, the setting menu appears.

Menu	Description	Available settings
<b>A. Alarm</b>	Set NIBP alarm.	Sys, Dia, Mean, PR
<b>A-1. Alarm</b>	Set whether to detect an alarm.	On, Off
<b>A-2. Priority</b>	Set alarm priority.	High, Medium, Low
<b>A-3. Low / High</b>	Set alarm low/high limit value.	
<b>A-4. Print</b>	Set print when an alarm occurs	
<b>B. Setup</b>	Setup menu	
<b>B-1. Cuff Size</b>	Set cuff size  * When changing the cuff, be sure to match the actual cuff size with the cuff size set on the monitor.	Small (~ #3), Large (#4~)
<b>B-2. Initial Pressure</b>	Set initial pressure.  Default settings: *Large Cuff : 170 mmHg *Small Cuff : 120mmHg	Large Cuff : 120 – 250 mmHg Small Cuff : 60 – 120mmHg
<b>B-3. Interval</b>	Set the blood pressure measurement cycle.  *Manual: Manual measurement *Others: Periodic measurement. After setting, press NIBP menu to start periodic measurement.	Manual, 1min, 2, 2.5, 3, 4, 5, 10, 15, 20, 30, 1hour, 1.5, 2, 4, 8
<b>B-4. Start Mode</b>	Set repeat measurement method.  *Clock: On-time measurement *Interval: Measure at the set interval	Interval, Clock
<b>B-5. PR Display</b>	Whether to display Pulse Rate	On, Off
<b>C. Review</b>	review recent blood pressure measurements (up to 1000)	

C-1. Latest / Prev /Next

Go to latest/previous/after page

**Warning**

- Check periodically to see if the circulation from the cuff to the distal part of the patient's arm is good.
- Check the patient's condition frequently when using the automatic measurement of 1 minute and 2-minute interval. It is not recommended for measuring blood pressure for a long time after the measurement time is set to 10 minutes or less.
- When changing the cuff, be sure to match the actual cuff size with the cuff size set in the monitor.

**Safety Considerations****Software and Hardware for Cuff pressure Blocking**

If the measurement time exceeds 2 minutes, the cuff is automatically reduced. Extension limits are established for all patient categories to prevent overpressurization of the patient.

The maintenance is performed every 2 years.

Check the following list to ensure the veterinary multiparameter monitor always operates properly and safely.

**Note**

1. Check for proper cuff size.
2. Check for residual air left in the cuff from a previous measurement.
3. Make sure cuff is not too tight or too loose.
4. Make sure cuff and heart are at same level, otherwise hydrostatic pressure will offset the NIBP value.
5. Minimize patient movement during measurement.
6. Watch for pulses paradox us.
7. Check for leak in cuff or tubing.

## 6) Measurement Restrictions

The measurement may be inaccurate or impossible:

- Measurements are impossible with heart rate extremes of less than 40 bpm or greater than 300 bpm.
- With excessive and continuous patient movement such as shivering or convulsions
- If a regular arterial pressure pulse is hard to detect
- With cardiac arrhythmias
- With rapid blood pressure changes
- With severe shock or hypothermia that reduces blood flow to the peripheries
- With obesity, where a thick layer of fat surrounding a limb dampens the oscillations coming from the artery
- On an edematous extremity

## 7) Selecting and Placing the Cuff

The quality of NIBP monitoring depends largely on the quality of the signals received by the monitor. For this reason, it is important to select the correct cuff size for your patient. Cuff sizes are clearly marked on the cuff. Measure the circumference of your patient's limb. Use only Bionet cuffs with your monitor.

### Warning

- **Non-invasive blood pressure monitors are not recommended for patients with hypotension, hypertension, arrhythmias, or extremely high or low heart rates. The software algorithm cannot accurately compute NIBP or patients with these conditions.**
- **Do not apply the cuff over a wound, as this can cause further injury.**
- **Since the value of NIBP may vary depending on the cuff size, the correct cuff size must be set in the measurement parameter menu**

setting before measurement.

- Tubes between the cuff and the patient monitor are not kinked or blocked. Air must pass unrestricted through the tubing.
- Pay attention not to block the connecting hose when you put cuff on patient.
- Periodically check the cuff or hose connections for leaks. Air leaks can cause inaccurate measurements.
- The cuff must be placed exactly on the arterial part.
- Even manual methods using a sphygmomanometer and stethoscope are ineffective in unstable or active patients.
- Pressurization of the cuff may result in loss of function of monitoring medical electrical devices used simultaneously on the same extremity.
- It is necessary to check that the operation of the NIBP does not cause organ damage to the patient's blood circulation.
- Devices that exert pressure on tissue have been associated with purpura, ischemia, and neuropathy. Inspect the application site regularly to ensure skin quality and inspect the extremity of the cuffed limb for normal color, warmth and sensitivity. If the skin quality changes, or if the extremity circulation is being affected, move the cuff to another site or stop the blood pressure measurements immediately. Check more frequently when making automatic or STAT measurements. Auto NIBP measurements with one- and two-minute intervals are not recommended for extended periods of time.
- NIBP reading can be affected by the measurement site, the position of the patient, exercise, or the patient's physiologic condition. If you doubt the NIBP measurements, determine the patient's vital signs by alternative means, and then verify that the patient monitor is working correctly.

## 8) Troubleshooting

This section lists the problems that might occur. If you encounter the problems when using the monitor or accessories, check the table below before contacting service representative. If the problem persists, contact your service representative.

Problem	Solution
<b>Weak or no oscillometric signal</b>	Check that the cuff is in the correct position. Check the patient. Check that the cuff is properly tightened. Check that there is no excessive clothing between arm and cuff. Check that the correct size cuff is being applied.
<b>Artifact / erratic oscillometric signal</b>	The patient may have been moving too much. Check that the cuff is in the correct position. Check that the correct size cuff is being applied.
<b>Out of Range BP Value /Exceeded measurement time limit</b>	The patient may have been moving too much. Check the patient. Patient may have serious BP-related issue. Check that the cuff is in the correct position. Check that the correct size cuff is being applied. Check that there is no excessive clothing between arm and cuff.
<b>Pneumatic Blockage</b>	Check that the hose has no sharp bends or is pinched. Check that the patient is not lying on the cuff. Check that the cuff is in the correct position.
<b>Inflate Timeout, Air Leak or Loose Cuff</b>	Check that the hose is connected to the system and the cuff. Check that the cuff is properly tightened. Check that the cuff is in the correct position. Check that the correct size cuff is being applied. Check that the cuff is not leaking air. Check that the hose connections are not damaged or loose.
<b>Safety Timeout</b>	Check the patient. Check that the cuff is in the correct position. The patient may have been moving too much.

	Take another BP reading.
<b>Cuff Overpressure</b>	<p>Check that the correct size cuff is being applied.</p> <p>Check that the hose has no sharp bends or is pinched.</p> <p>Check that the cuff is in the correct position.</p> <p>Check that the patient is not lying on the cuff.</p>

## 9) Calibration

1. Menu -> Calibration -> Parameter Calibration
2. Enter Password.
3. Select NIBP Tab.
4. NIBP ZERO: Press the [Zero] button with no pressure on the cuff.

NIBP Gain : Press the Calibration button while applying a pressure of 250mmHg for the Suntech NIBP module using the JIG.

### Warning

- **Calibration procedures may only be performed by service representative or designated trained personnel.**
- **To reduce the risk of injury, do not perform any in-use calibration procedures on the patient.**
- **Incorrect calibration values may result in patient harm.**

## PART 12. Temperature

### 1) Overview

The Brio Series monitor can continuously monitor the patient's temperature via the Temp module. It uses a heat-sensitive resistor (thermistor) and is based on the principle that the electrical resistance of the thermistor changes with temperature change. The change in resistance of the resistor is used to calculate the temperature.

### 2) Preparing the Patient

Select an appropriate probe for your patient according to patient species and measured site.

### 3) Connector and measurement cable

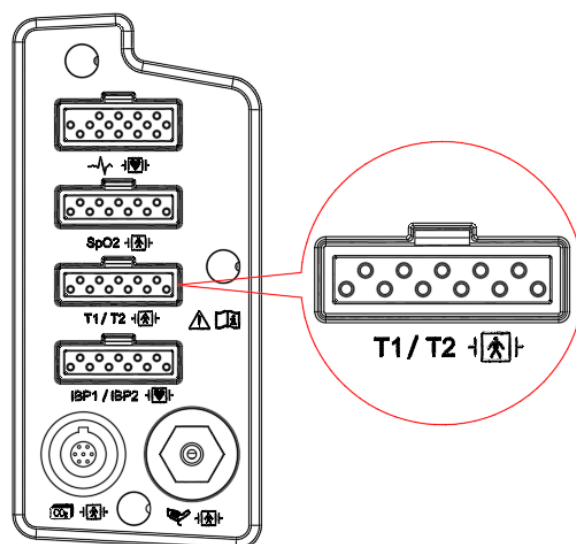

#### Brio X3VET

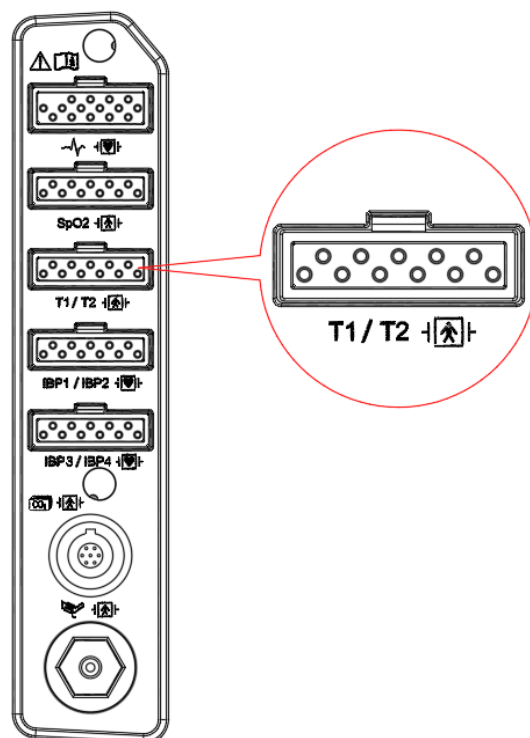

**Brio X5VET , Brio X7VET**



**Temperature measurement sensor and cable**

	<p><b>Temperature measurement cable</b></p>
	<p><b>Temperature measurement sensor</b></p>

<p><b>Note</b></p>	<p>Correctly position the temperature probe and fix it not to be disconnected from the patient.</p>
--------------------	---

## 4) Display

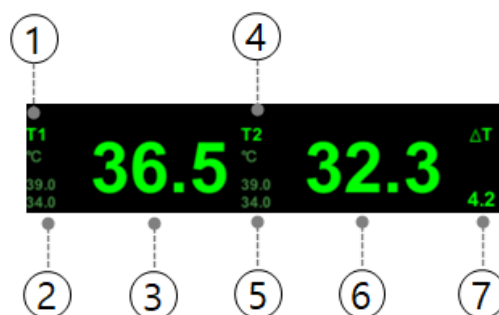

- ① T1 temperature label
- ② T1 temperature unit and alarm limit
- ③ T1 temperature value
- ④ T2 temperature value
- ⑤ T2 temperature unit and alarm limit
- ⑥ T2 temperature value
- ⑦ Temperature difference

### Note

- The minimum measuring time required to obtain accurate readings at the specific body site is at least three minutes.
- If the measurement site like the patient's skin is directly exposed to air, the temperature may be lower than normal.
- It takes about 20 ~ 30 minutes to reach temperature equilibrium by attaching this sensor.

## 5) Temp Setting Menu

When you select the Temp numerical area, the setting menu appears.

Menu	Description	Available settings
<b>A. Alarm</b>	Set Temp alarm.	Temp1, Temp2, DT
<b>A-1. Alarm</b>	Set whether to detect an alarm.	On, Off
<b>A-2. Priority</b>	Set alarm priority.	High, Medium, Low
<b>A-3. Low / High</b>	Set alarm low/high limit value.	
<b>A-4. Print</b>	Set print when an alarm occurs.	
<b>B. Setup</b>	Setup menu	
<b>B-1. View Channels</b>	View Channel.	T1 T2 T1, T2
<b>B-2. Delta Display</b>	Decide whether to display Delta Temp. Shown when View Channels is T1, T2.	On, Off

## 6) Troubleshooting

This section lists the problems that might occur. If you encounter the problems when using the monitor accessories, check the table below before requesting service. If the problem persists, contact your service representative.

Problem	Solution
"---" is displayed in place of numeric.	Try using a known good probe in case the sensor is damaged.

## PART 13. EtCO<sub>2</sub>

### 1) Overview

The Brio XVET Series monitor measures concentrations of end-tidal CO<sub>2</sub> (EtCO<sub>2</sub>) when this option is enabled and the EtCO<sub>2</sub> module is connected to your monitor. Both mainstream and sidestream measurements use infrared light. The intensity of infrared light passing through the breathing gas is measured with a photodetector. Because some of the infrared radiation is absorbed by the CO<sub>2</sub> molecules, the amount of light passing through the gas probe depends on the measured CO<sub>2</sub> concentration. When using a ventilator, monitor CO<sub>2</sub> as a mainstream measurement rather than a side stream. Measurements are taken at the patient's airway at a sampling frequency of 100 Hz, so response is faster and there is less chance of erroneous, artifact data.

The EtCO<sub>2</sub> module can perform mainstream measurements in all monitoring modes and sidestream measurements in the large animal monitoring modes. For side stream measurements, the capnostat fits on the nasal sampling cannula tubing.

### 2) EtCO<sub>2</sub> Caution

#### Warning

- The safety and effectiveness of respiration measurement methods in detecting apnea have not yet been established.
- Veterinary multiparameter monitors that measure CO<sub>2</sub>, anesthetics, and/or respiratory mechanics cannot be used as apnea monitoring and/or recording equipment. While these monitors provide an apnea alarm, the alarm condition begins with the elapsed time from when the last breath was detected. However, there are several physiological indications for the clinical diagnosis of real apnea events.
- The CO<sub>2</sub> alarm is not activated until the first breath is detected after the veterinary multiparameter monitor is turned on or the patient is discharged.
- Accuracy of the CO<sub>2</sub> and breathing rate measurements may be impaired

due to improper attachment of the sensor or due to certain patient conditions and certain environmental conditions.

- If the tube connection is faulty, loose or damaged, gas may leak and the accuracy of the measurement may be lowered, resulting in poor breathing. To prevent this, connect all component securely and check the connection according to standard clinical procedures to ensure that there are no leaks.

### Warning

- **Industrial safety:** Carefully dispose used sampling tubes and T-connectors as they may cause infection. There is a risk of infection. Dispose of all equipment in accordance with local regulations.
- Optimize reaction time by minimizing dead space and keeping sample collection tubes as short as possible. Long sampling tubes can lead to poor accuracy and slow response times for side stream measurement techniques.
- Do not place the airway adapter between the suction catheter and the endotracheal tube when using the sample collection line as a closed suction device for tuberculous patients. This is to ensure that the airway adapter does not interfere with the function of the suction catheter.

### 3) Connector and Measurement Accessory

#### Brio X3VET

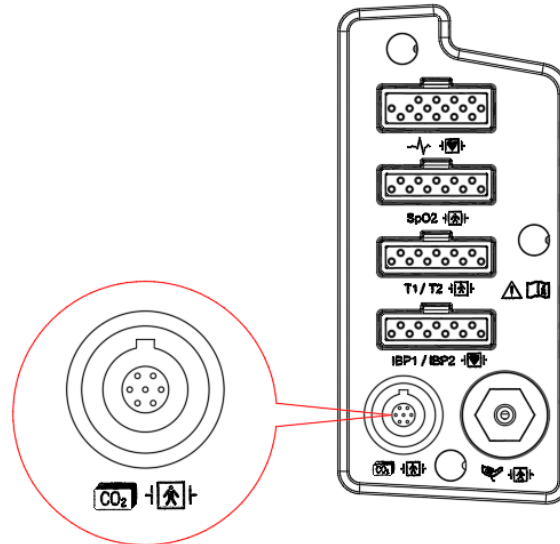

#### Brio X5VET , Brio X7VET

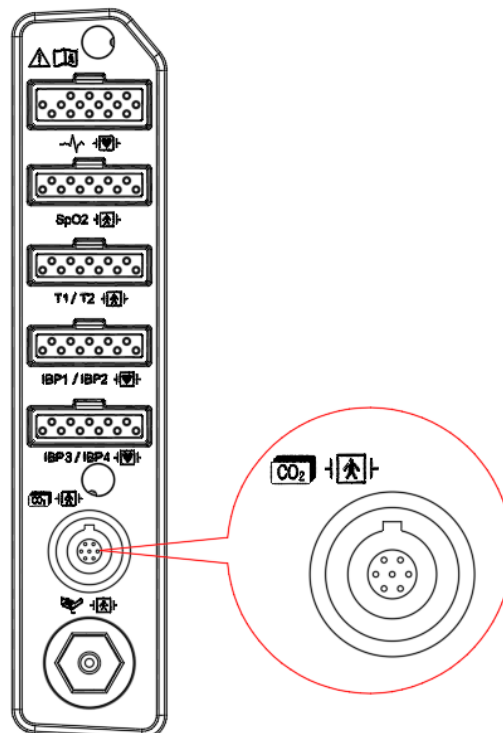

## LoFlo Sidestrem CO2 sensor and connector





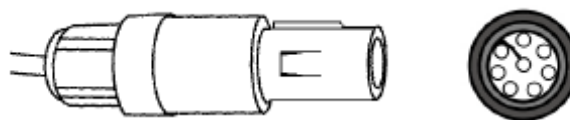



Sidestream sensor



Sidestream sensor connector

## Sidestream EtCO2 Accessories

Non-Intubation Sidestream Accessories			
Part	Picture	Description	type
3468ADU-00		Nasal CO2 sampling cannula	Large animal
3468PED-00		Nasal CO2 sampling cannula	Large animal
3469ADU-00		Nasal CO2 sampling cannula w/O2 delivery	Large animal
3469PED-00		Nasal CO2 sampling cannula w/O2 delivery	Large animal
3469INF-00		Nasal CO2 sampling cannula w/O2 delivery	Small animal

Intubation accessories			
3473ADU-00		Airway adapter kit w/ dehumidification tubing	Large animal (cat/dog/horse) (ET tube Size > 4.0 mm)

3473INF-00		Airway adapter kit w/ dehumidification tubing	Small animal (others) (ET tube size <= 4.0 mm)
------------	---	--	---

**CAPNOSTAT 5 Mainstream CO2 sensor and connector**





**Mainstream Sensor**



**Mainstream Sensor Connector**

**Mainstream EtCO2 Accessories**

Intubation patient airway adaptor		
Model	Picture	Description
6063-00		Large animal (Cat/Dog/Horse) (disposable)
6312-00		Small animal (others) (disposable)

7007-01		Large animal (Cat/Dog/Horse) (recycle)
7053-01		Small animal (others) (recycle)

**Warning**

**The disposable airway adapters are designed for single use only and cannot be reused. Reuse may cause inaccurate readings, erratic readings, or no readings at all. Also, reuse may cause an increased risk of cross contamination among patients.**

**The reusable airway adapters can be reused but to avoid infection, it shall be reused only after sterilized.**

#### 4) CO<sub>2</sub> Measurement Restrictions

The following factors may affect measurement accuracy:

- Sample gas leakage or internal emission
- Mechanical impact
- Periodic pressure of up to 10 kPa (100 cmH<sub>2</sub>O)
- High concentration of nitrous oxide gas
- Rapid temperature change
- High humidity
- Other interference factors

**Warning**

**Measurement accuracy of the sidestream CO<sub>2</sub> module may be affected by the breath rate and inspiration/expiration (I/E) ratio.**

<b>Caution</b>	<ul style="list-style-type: none"><li>● The measured values may be inaccurate when using the veterinary multiparameter monitor for patients who have very fast or irregular respiration.</li><li>● When measuring CO<sub>2</sub> from the patient under the anesthesia, check it when gas mixture comes in. Otherwise, the measured result values may be inaccurate.</li><li>● When using an anesthesia machine that uses a volatile anesthetic, CO<sub>2</sub> values may be inaccurate.</li></ul>
----------------	---

## 5) Display

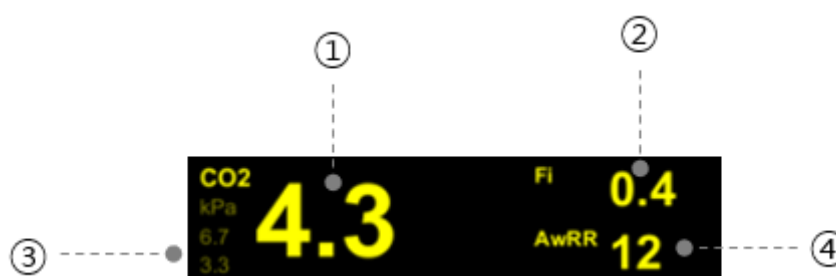

- ① End tidal CO<sub>2</sub> value (EtCO<sub>2</sub>)
- ② Fraction of inspired CO<sub>2</sub> (FiCO<sub>2</sub>)
- ③ EtCO<sub>2</sub> alarm high/low limit value
- ④ Airway respiration rate

## 6) How to Sample

### Connecting the CAPNOSTAT® 5 CO<sub>2</sub> sensor to the host system

1. Insert the CAPNOSTAT 5 CO<sub>2</sub> sensor connector into the receptacle of the host monitor as shown in Figure 1.

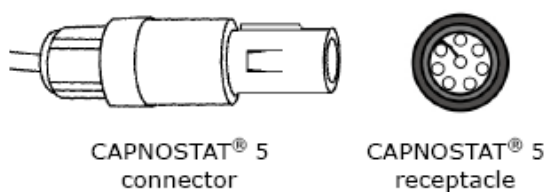

*Figure 1*

2. Make sure the arrows on the connector are at the top of the connector, and line up the two keys of the connector with the receptacle and insert.
3. To remove the connector, grasp the body portion of the connector back and remove.

**Caution** Do not remove by pulling cable.

### Connecting the mainstream CO2

1. Connect the CAPNOSTAT 5 CO<sub>2</sub> sensor to the Respironics Novamatrix CO<sub>2</sub> adapter as shown below. The airway adapter clicks into place when seated correctly.

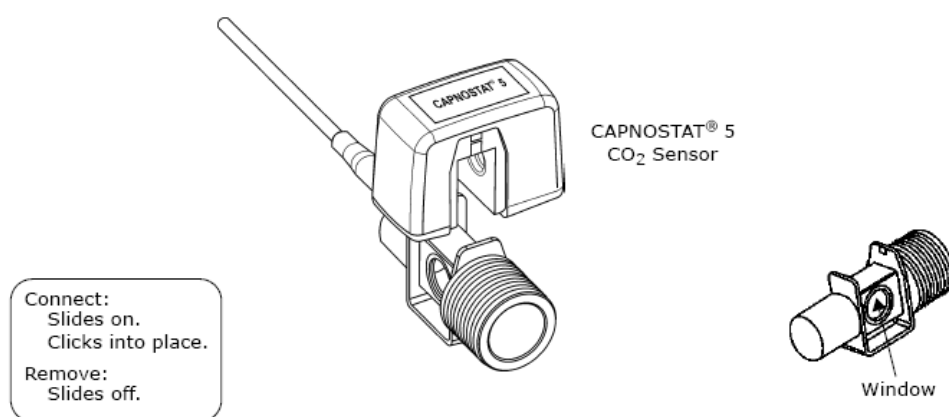

**Note** If zeroing is required, do this step. For details, see Zero Calibration.

2. Shown below is the CAPNOSTAT 5 CO<sub>2</sub> Sensor with a patient circuit

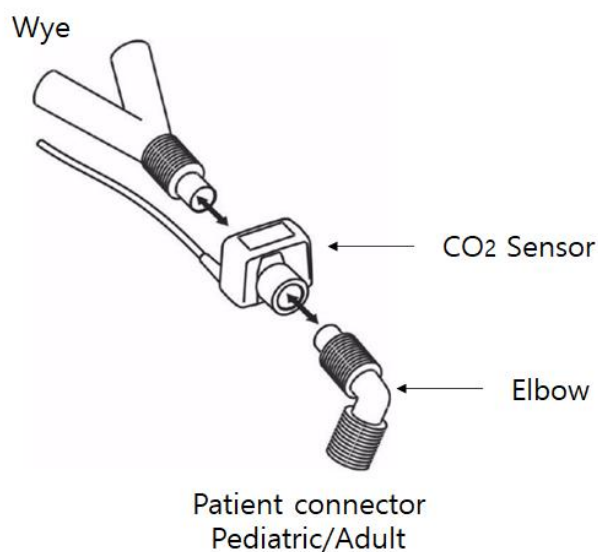
**Warning**

- To prevent stress on the endotracheal tube, support the sensor and airway adapter.
- Position sensor cables and tubing carefully to avoid entanglement or potential strangulation. Do not apply excessive tension to any cable.
- Replace the airway adapter, if excessive moisture or secretions are observed in the tubing or if the CO2 waveform changes unexpectedly without a change in patient status.
- To avoid infection, use only sterilized, disinfected, or disposable airway adapters.
- Inspect the airway adapters prior to use. Do not use if airway adapter appears to have been damaged or broken. Observe airway adapter color coding for patient population.

**Connecting the sidestream CO2 (LoFlo Sample Kit)**

1. The sample cell of the sampling kit must be inserted into the sample cell receptacle of the LoFlo CO2 Module as shown in Figure 1. A "click" is heard when the sample cell is properly inserted.

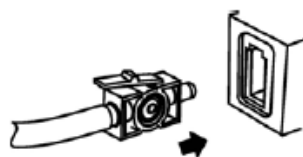

Figure 1

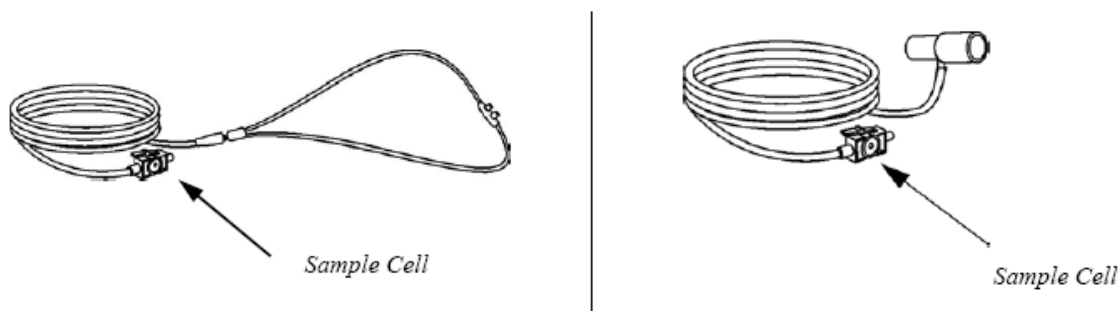

Figure 2

Inserting the sample cell into the receptacle automatically starts the sampling pump.

Removal of the sample cell turns the sample pump off.

To remove the sampling kit sample cell from the sample cell receptacle, press down on the locking tab and pull the sample cell from the sample cell receptacle.

**Note**

**If zeroing is required, do this step for details, see Zero Calibration.**

- For intubated patients requiring an airway adapter: Install the airway adapter at the proximal end of the circuit between the elbow and the ventilator Y-section.

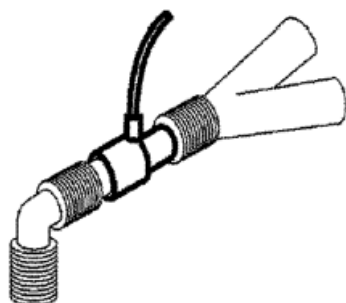

For intubated patients with an integrated airway adapter in the breathing circuit: Connect the male luer connector on the straight sample line to the female port on the airway adapter.



For non-intubated patients: Place the nasal cannula onto the patient.

For patients prone to mouth breathing use an oral-nasal cannula. For nasal or oral-nasal cannulas with oxygen delivery, place the cannula on the patient as shown. Then attach the oxygen supply tubing to the oxygen delivery system and set the prescribed oxygen flow.

**Warning**

- Always connect the airway adapter to the sensor before inserting the airway adapter into the breathing circuit. In reverse, always remove the airway adapter from the breathing circuit before removing the sensor.
- Make sure that you do not accidentally connect the luer connector of the gas sample line to an infusion link or any other links in the patient vicinity.

**Caution**

Always disconnect the cannula, airway adapter or sample line from the sensor when not in use.

**Removing Exhaust Gases from the System****Warning**

- Connect the gas outlet to the scavenging system when measuring CO<sub>2</sub> using the side stream CO<sub>2</sub> module.
- Anesthetics: When using the side stream CO<sub>2</sub> measurement on patients who are receiving or have recently received anesthetics, connect the outlet to a scavenging system, or to the anesthesia machine/ventilator, to avoid exposing medical staff to anesthetics.

Use an exhaust tube to remove the sample gas to a scavenging system. Attach it to the sidestream sensor at the outlet connector.

## 7) Zero Calibration

Perform zero calibration when you connect the CAPNOSTAT 5 CO<sub>2</sub> sensor to the monitor for the first time or when replacing the airway adapter.

1. Expose the sensor to room air and keep it away from all sources of CO<sub>2</sub> including the ventilator, the patient's breath and your own.
2. From the CO<sub>2</sub> setup menu, launch the Zero menu and the CO<sub>2</sub> waveform displays a "Zeroing" message.
3. When the "Zeroing" message disappears, zero calibration is complete, and monitoring can begin.

### Caution

- For mainstream CO<sub>2</sub>, connect the sensor to the adapter and wait 2 minutes before zeroing the adapter.
- For sidestream CO<sub>2</sub>, connect the gas outlet to the scavenging system when calibrating the CO<sub>2</sub> module.
- A zero calibration is performed the first time a monitor is connected. Then do zeroing each time you install an adapter of a different style, such as changing from reusable to single use, or the system prompts you to perform zeroing. Zero calibration is not necessary when you change the type within the same adapter style.
- The figures shown are invalidated within 30 seconds of the start of calibration/zero Calibration.

## 8) EtCO2 Setting Menu

When you select the EtCO2 numerical or waveform area, the setup menu appears.

Menu	Description	Available Settings
<b>A. Alarm</b>	EtCO2 alarm setup menu	EtCO2, FiCO2, AwRR, ZeroRR
<b>A-1. Alarm</b>	Set whether to detect an alarm.	On, Off
<b>A-2. Priority</b>	Set alarm priority	High, Medium, Low
<b>A-3. Low / High</b>	Set alarm low/high limit value.	
<b>A-4. Print</b>	Set print when an alarm occurs.	
<b>B. Setup</b>	Setup menu	
<b>B-1. Speed</b>	Set waveform range speed.	6.25 mm/sec 12.5 mm/sec 25.0 mm/sec
<b>B-2. Size</b>	Set waveform size  The values that can be selected are the maximum pressure range values shown as waveforms.  The size value set in the waveform area is displayed.	40mmHg (5.0 %, kpa) 50mmHg (6.5 %, kpa) 60mmHg (8.0 %, kpa) 80mmHg (10.0 %, kpa) 100mmHg(13.0 %, kpa) 150mmHg(20.0 %, kpa)
<b>B-3. Fill</b>	Choose whether to fill the waveform inside.	On, Off
<b>C. Module setup</b>	EtCO2 module setup menu	
<b>C-1. Current period</b>	This setting is used to set the calculation period of the ETCO2 value. The end-tidal CO2 value is the highest peak CO2 value of all ends of expirations (end of breaths) over the selected time period. If less than two breaths exist in the selected time period, the value is the maximum ETCO2 value for the last two breaths.	1 breath, 10 sec, 20 sec

<b>C-2. Balance gas</b>	This setup mode to setup the gas in the measurement. the type of gas that is mixed with the breathing gas measuring.	Room air N2O Helium
<b>C-3. Operating mode</b>	Sleep and Standby are used to conserve power when the main unit goes to standby. * Sleep stays warmed up to use Capnostat immediately upon exiting Sleep mode * Standby requires a warm-up process and there may be a delay until the system is stably ready.	Measure Sleep Standby
<b>C-4. Barometric Pressure</b>	Set ambient barometric pressure.  *Default: 760 mmHg	
<b>C-5. Gas temperature</b>	This setting is used to set temperature of the gas mixture. This setting is useful when bench testing using static gasses where the temperature is often room temperature or below.  *Default: 35.0 °C	
<b>C-6. O2 compensation</b>	Use this setting to correct for the compensation of the gas mixture administered to the patient. * Default: 16%	
<b>C-7. Anesthetic agent</b>	Anesthetic agent is ignored when the balance gas is set to helium.	
<b>C-8. Zero</b>	Zero calibration	

<b>Note</b>	<b>Set the menu only when the EtCO2 module is in monitoring status.</b>  <b>If it is set when the EtCO2 module is not in a monitoring state such as Startup, Sleep, Standby, or Zeroing, it may not be applied.</b>
-------------	---

## 9) Troubleshooting

This section lists the problems that might occur. If you encounter the problems when using the monitor or accessories, check the table below before requesting service. If the problem persists, contact your service.

Problem	Solution
EtCO <sub>2</sub> measurements too low	<ol style="list-style-type: none"><li>1. Check the patient status.</li><li>2. Check the sample line and connectors for leakage.</li><li>3. Ventilate the room if the environmental CO<sub>2</sub> concentration is too high.</li></ol>
CO <sub>2</sub> value is not output, or numerical error.	<ol style="list-style-type: none"><li>1. Check the connection between the main unit and the module.</li><li>2. Check the module line connection with the filter line or airway.</li><li>3. Replace filter line or airway.</li></ol>

## PART 14. Invasive Blood Pressure (IBP)

### 1) Overview

It converts the changes in resistance components, which are caused by the changes in the blood flow in the blood vessels, into electrical signals, and measures the minimum, maximum, and average blood pressures through signal processing.

### 2) Precautions

The following precautions apply to IBP procedures. See the hospital's clinical guidelines for details.

#### Warning

- All parts, except Transducer, should not be conductive. Otherwise discharge energy may induce a shock to operators during cardioversion.
- Single-use accessories are not to be reused.
- Use of non-approved transducers may compromise this protection.
- When the monitor is connected to electrosurgical units, make sure the transducers and cables do not make contact with the electrosurgical unit. The patient lead and conducting wire must be far away from the operating table and other devices. The electrosurgical unit should be properly grounded.
- When the monitor is connected to high frequency electrosurgical equipment, do not allow the sensor from the monitor to come into contact with the high frequency electrosurgical equipment or its cables. Otherwise, electric leakage may occur and may cause burns to the patient.

#### Note

- Check if there is a scratch on the catheter balloon before using.
- Do not reuse disposal parts and accessories.
- Do not use saline packs with passed expiration dates.

- Do not use the pressure measurement kits in torn packages.
- Remove all air in the saline pack by squeezing it. Otherwise, it may cause errors in blood pressure band and may go into the blood vessels.

### Defibrillator on a Patient

IBP transducers must comply with the requirements of IEC 60601-2-34, must be provided with defibrillator protection, have a frequency response exceeding 15Hz and contribute not more than 2mmHg to the overall measurement error.

#### Warning

- Patient signal inputs labeled with the CF and BF symbols with paddles are protected against damage resulting from defibrillation voltages. To ensure proper defibrillator protection, use only the recommended cables and lead wires. Do not reuse the single-use entropy electrodes.
- Proper placement of defibrillator pads in relation to the electrodes is required to ensure successful defibrillation.

## 3) Connector and Measurement Kit

### Brio X3VET

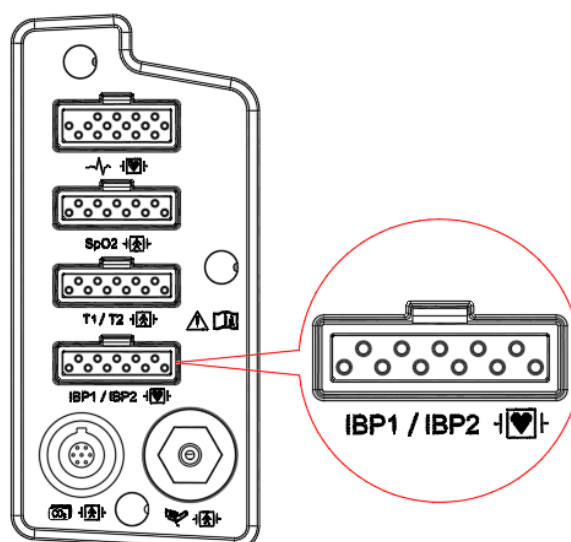

**Brio X5VET , Brio X7VET**

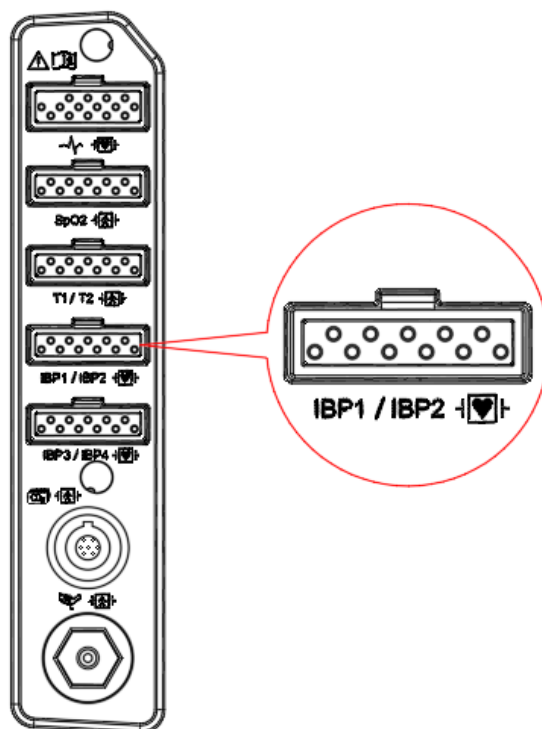

**IBP Cable**

Model No	Description
152600-042800	Medex/Abbott/Ace medical IBP Cable
152600-042900	Edwards/Baxter IBP Cable
152600-042400	BD/Datex Ohmeda IBP Cab
152600-043400	Medex/ Logical IBP Cable

**IBP Accessory**

For IBP accessories other than Ace Medical and Smiths Medical manufacturer, contact the accessory manufacturer.

Manufacturer: Ace Medical	
Model No	Description
AMK 150	IBP Single Kit

AMK 250	IBP Double Kit
---------	----------------

Manufacturer: Smiths Medical	
Model No	Description
MX9504T	Single Line Monitorin Kit
MX800	Modular transducer mounting plate
MX240	Pole clamp for mounting a transducer plate
MX4810	C-Fusor 1000ml Pressure Infusor complete unit with squeeze bulb and pressure gauge

## 4) Display

IBP is displayed in two forms as shown in the selected label below. For label description, refer to the IBP measurement parameter label list and description.

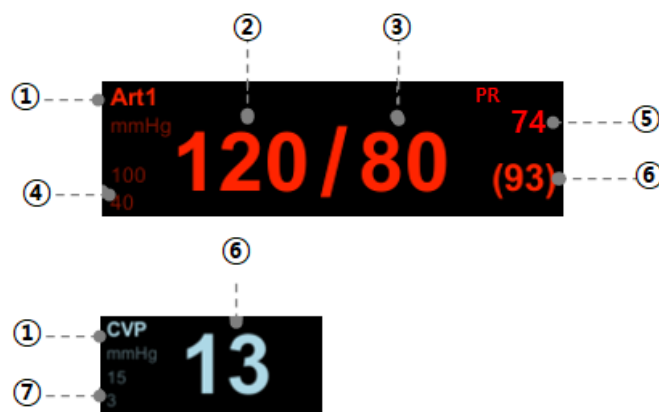

- ① IBP label: Measuring Position
- ② Systolic blood pressure: Indicates the maximum blood pressure
- ③ Diastolic blood pressure: Indicates the minimum blood pressure

- 
- ④ Alarm upper/lower limits for systolic or diastolic blood pressure: When the systolic blood pressure alarm is off, the alarm upper/lower limits for diastolic blood pressure are displayed.
  - ⑤ Pulse rate
  - ⑥ Mean blood pressure: Indicates the average blood pressure
  - ⑦ Alarm upper/lower limit of mean blood pressure

## 5) Procedures

### Zeroing

1. Close the transducer stopcock on the patient's side.
2. Open the venting stopcock on the air side.
3. Press the knob switch on the monitor panel.
4. Draw a line with the current input data in IBP area of wave window according to the wave base line. Align the wave line with the data.
5. Zeroing is performed by executing the Zero menu of IBP Setting or the "Zero IBP" menu at the bottom of the screen. When zeroing is complete, a notification window appears.
6. Check the pressure parameter on the message window.
7. Close the venting stopcock on the air side.
8. Open the transducer stopcock on the patient side. The pressure value should be displayed on the pressure parameter screen in a few seconds.

## 6) List & Description of IBP Measurement Parameter Label

Parameter window, Scales menu window or Alarm limits pop-up menu appears according to the Labels.

IBP displays the measuring positions based on 10 labels shown in the below table.

Select "User Defined" for a measuring position not in the listed positions.

Label	Description	Display Value
Art1, Art2	Arterial blood pressure(alternative)	systolic, diastolic, and mean
Fem	Femoral pressure	systolic, diastolic, and mean
PAP	Pulmonary artery pressure	systolic, diastolic, and mean
CVP	Central venous pressure	mean
LAP	Left atrial pressure	mean
RAP	Right atrial pressure	mean
ICP	Intracranial pressure	mean
User Defined	Other	systolic, diastolic, and mean
UAP	Umbilical arterial pressure	systolic, diastolic, and mean
UVP	Umbilical venous pressure	mean

The table below shows the default waveform size settings by label.

Label	Horses,Dogs, Cats (large animals) (mmHg)	Others (small animals) (mmHg)
Art1, Art2	160	100
Fem	160	100
UAP	160	100
PAP	60	60
CVP	30	30
RAP	30	30
LAP	30	30
UVP	30	30
ICP	30	30
User Defined	160	100

## 7) IBP Setting Menu

When you select an IBP numerical or waveform area, the setup menu appears.

Menu	Description	Available settings
<b>A. Alarm</b>	Set IBP alarm.	Sys, Dia, Mean, PR
<b>A-1. Alarm</b>	Set whether to detect an alarm.	On, Off
<b>A-2. Priority</b>	Set alarm priority	High, Medium, Low
<b>A-3. Low / High</b>	Set alarm low/high limit value.	
<b>A-4. Print</b>	Set print when an alarm occurs.	
<b>B. Setup</b>	Setup menu	
<b>B-1. Label</b>	Set measuring position.	Art1, Art2, Fem, PAP, RAP, LAP, UAP, UVP, CVP, ICP, User Defined
<b>B-2. Speed</b>	Set waveform range speed.	6.25 mm/sec, 12.5 mm/sec, 25.0 mm/sec, 50.0 mm/sec
<b>B-3. Size</b>	Set size of measurement waveform on screen.	30, 60, 80, 100, 160, 200, 300 mmHg (4.0, 8.0, 10.0, 13.0, 21.0, 27.0, 40.0 kpa)
<b>B-4. Auto Size</b>	Set automatic waveform size. Set to the size that best shows the current systolic or mean blood pressure	
<b>B-5. BP Filter</b>	Menu to set filter *Off: 0Hz ~ 40Hz *12Hz: 0Hz ~ 12Hz *20Hz: 0Hz ~ 20Hz (default)	Off / 12Hz / 25Hz
<b>B-6. PR Display</b>	PR Display Setup	Off / On
<b>B-7. Zero</b>	IBP zeroing	
<b>B-8. Latest zeroing time</b>	Last zeroing time information (date, time) display	

## 8) Troubleshooting

This section lists the problems that might occur. If you encounter the problems when using the monitor or accessories, check the table below before requesting service. If the problem persists, contact your service representative.

Problem	Solution
"---" is displayed in place of numeric.	<ol style="list-style-type: none"> <li>1. Check the connection of IBP cable, IBP transducer.</li> <li>2. Check that the three-way valve is turned to the correct position.</li> <li>3. Check that the IBP transducer has been zero calibrated.</li> <li>4. It may be outside the measurement range. Check the measurement conditions.</li> <li>5. If the blood pressure transducer is damaged, replace it with a new one.</li> </ol>
IBP readings seem unstable	<ol style="list-style-type: none"> <li>1. Make sure there are no air bubbles in the transducer systems.</li> <li>2. Check that the transducer is properly fixed.</li> <li>3. Zero the transducer again.</li> <li>4. Replace the transducer.</li> </ol>
Zeroing of IBP channel(s) fails.	<ol style="list-style-type: none"> <li>1. Ensure that the channels are open to air.</li> <li>2. Perform zeroing again. Do not sway the IBP transducer and tubing during the calibration.</li> <li>3. If zeroing still fails, replace the transducer.</li> </ol>

# PART 15. Anesthetic Gas (AG) – Dual Gas module

## 1) Overview

The dual gas module extracts a gas sample from the patient's breathing gas. It continuously measures CO<sub>2</sub> and anesthetics (Isoflurane, Sevoflurane and Desflurane) in the breathing gas. All measured values as well as derived values are passed to the patient monitor.

Bionet offers the following dual gas modules.

- BDGA Sidestream Analyzer (Bionet)

## 2) Connectors and Accessories



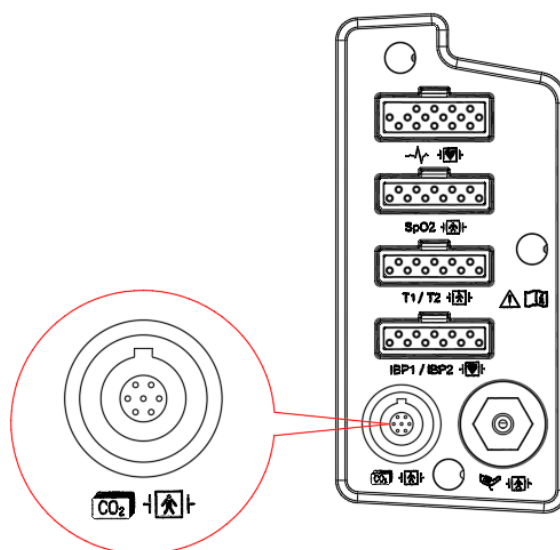

Brio X3VET

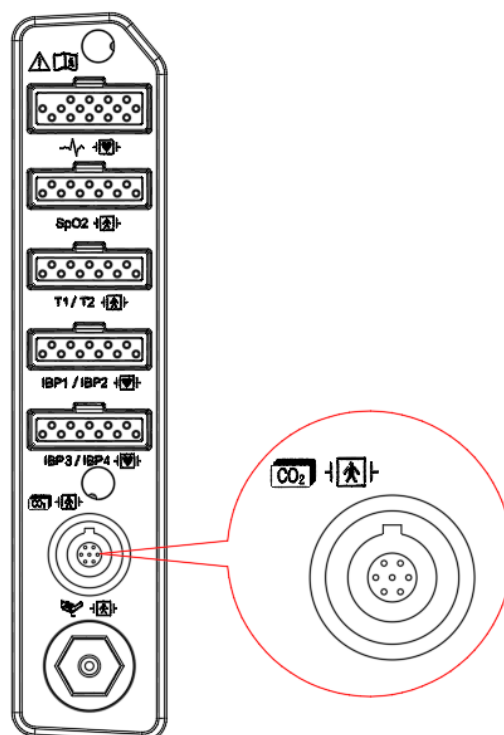

## Brio X5VET, Brio X7VET



## Accessory

Item Code	Item Image	Product Description
DGA-WT		Water Trap
DGA-SL		Sample Line with Luer Lock (8')
DGA-AAS		Airway Adapter (straight)
DGA-AAL		Airway Adapter (L type)

## Dual gas module



The Dual Gas Module is a side-by-side multi-gas analyzer that measures end-tidal carbon dioxide (EtCO<sub>2</sub>) and manually selects one of three anesthetics (isoflurane, sevoflurane, and desflurane).

### Measure gas

- EtCO<sub>2</sub>
- Isoflurane
- Sevoflurane
- Desflurane

### Benefits of Anesthetic Gas Monitoring

- Simultaneously monitors CO<sub>2</sub> and anesthetic gas, alarming if values are out of range.
- Monitor maintenance of anesthesia via MAC parameters.
- May help prevent overdose of anesthetic gas.
- Monitor anesthetic gas concentrations to ensure proper functioning of the vaporizer.
- Record the amount of anesthetic gas in the procedure.

### Advantages and Features

- A low-cost, durable and proven sidestream technology that accurately measures both EtCO<sub>2</sub> and anesthetic concentrations (3 anesthetics to choose from).
- 30 second warm-up time and fast response time at system startup.
- Perform system calibration to maintain accurate performance, as using an infrared (IR) light source with optical band-pass filtering technology may detract from the dual-gas system from frequent or routine high calibration (gain calibration) procedures using a calibration gas. You can get rid of the daily hustle and bustle of doing it.
- Zero calibration ensures that the system performs accurately regardless of the environment.

- Exclusive advanced pneumatic and filtering systems provide maximum system protection and safety in sidestream technology.
- Large water trap filter system allows continuous use of dual gas modules even in wet conditions without frequent water trap replacement. Many other modules use moisture absorbing filters that require frequent filter changes.
- Water level sensing prevents excessive moisture for safe operation.
- Provides EtCO<sub>2</sub>, FiCO<sub>2</sub>, respiratory rate, anesthetic agent concentration and minimum alveolar concentration (MAC) parameters.

### 3) MAC value

The MAC value may be calculated and displayed by using end-tidal (ET) gas concentrations according to the following formula:

$$\text{MAC} = \%ET(\text{AA1})/X(\text{AA1})$$

\* X(AA)

	Horse	Dog, Other	Cat
Iso	1.3 %	1.3 %	1.6 %
Sev	2.3 %	2.4 %	2.6 %
Des	8.1 %	7.2 %	9.8 %

\*The altitude and the patient age as well as other individual factors are not taken into account in the above described formula.

### 4) Display function



- ① EtCO<sub>2</sub> alarm upper/lower limit display
- ② End-tidal carbon dioxide concentration value
- ③ Inspiratory carbon dioxide concentration value
- ④ Airway breathing rate per minute
- ⑤ Displays set anesthetic gas type and unit, end-stage (Et) alarm upper/lower limit value
- ⑥ Et value of set anesthetic gas
- ⑦ MAC value
- ⑧ Expiration (Fi) value of the set anesthetic gas

## 5) Dual gas setup

Menu	Description	Available settings
<b>A. Alarm</b>	Anesthetic gas (AG) parameter alarm setting	EtCO <sub>2</sub> , FiCO <sub>2</sub> , AwRR, ZeroRR, EtAA, EtAA
<b>A-1. Alarm</b>	Alarm detection setting	On, Off
<b>A-2. Priority</b>	Alarm priority setting	High, Medium, Low
<b>A-3. Low / High</b>	Alarm lower/high limit value setting	
<b>A-4. Print</b>	Print settings when an alarm occurs	
<b>B Setup</b>	<b>settings menu</b>	
<b>B-1. Speed</b>	Sweep Speed setting	6.25mm/s, 12.5mm/s, 25mm/s
<b>B-2. Size</b>	Waveform size setting  The value that can be selected is the value of the maximum pressure range shown in the waveform.  The set Size value is displayed in the waveform area.	40, 50, 60, 80, 100, 150, 300, 500, 800, 1000mmHg (5.0, 6.5, 8.0, 10.0, 13.0, 20.0 40.0, 65.0, 100.0, 130.0 % , kpa)
<b>B-3. Wave Fill</b>	Select whether or not to fill in the inside of the waveform	On, Off

---

<b>B-4. Waveform Type</b>	Select Gas Waveforms to Display	CO2, AG
<b>B-5. Operating mode</b>	Mode setting for dual gas module Standby mode when not in use When used, it is used in Measure mode.	Measure, Standby
<b>B-6. Anesthetic Gas</b>	Anesthetic gas setting,	Iso, Sev, Des

---

## PART 16. Anesthetic Gas (AG) – ParaMount module

### 1) Overview

The anesthetic gas (AG) module is connected to the intubated patient's airway or collects gas from designated accessories to measure the patient's anesthesia and respiratory gas. It also integrates the functions of the O2 module.

The AG module uses infrared (IR) absorption measurements to determine the concentration of a particular gas. Each gas has its own absorption characteristics. The gas is transported through the sample unit, and the optical IR filter selects IR light in a specific band through the gas. Multiple IR filters exist for multiple gas measurements. At a given volume, the higher the gas concentration, the more IR light it absorbs. This means that if the IR absorption gas concentration is high, the IR light transmittance decreases. The concentration of gas present can be calculated by measuring the amount of IR light transmitted through the gas.

Oxygen does not absorb infrared rays like other respiratory gases, so it is measured by irregular distribution characteristics. Inside the O2 sensor, there are two nitrogen-filled glass balls mounted on a strong, rare metal band suspension. This component is suspended from a symmetric non-uniform magnetic field. In the presence of paramagnetic oxygen, the glass sphere is pushed farther away from the strongest part of the magnetic field.

The torque intensity acting on the suspension is proportional to the oxygen concentration. The oxygen concentration is calculated from the torque strength.

AG monitoring is for large animals and small animals.

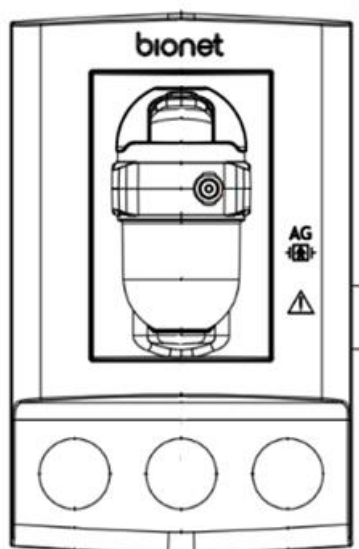
**Note**

The AG module is configured with automatic barometric pressure compensation.

**Warning**

- Please measure in a well-ventilated environment.
- EtCO<sub>2</sub> values measured by AG modules may differ from those measured by blood gas.
- The emptying interval of the large animal watertrap is 26 hours @ 120 ml/min, sample gas of 37 °C, room temperature of 23 °C, and relative humidity is 100%.
- The emptying interval of the small animal watertrap is 35 hours @ 90 ml/min, sample gas of 37 °C, room temperature of 23 °C, and 100% RH.

**Caution**

- Connect the Paramount module cable with the monitor powered off.
- To prevent explosion, do not use flammable anesthetics such as ether or cyclopropane in the veterinary multiparameter monitor.
- High frequency electrosurgical devices may increase the risk of skin burns. Do not use antistatic or inverted respiratory tubes.
- Remove all tubes from the patient's neck to avoid strangulation.

<b>Note</b>	<p>The AG module automatically suppresses physiological alarms until a breathing wave is detected.</p> <p>Make sure the patient is properly connected when monitoring with the AG module.</p>
-------------	---

## 2) AG Measurement Restriction

The following factors may affect measurement accuracy:

- Sample gas leakage or internal emission
- Mechanical impact
- Periodic pressure of up to 10 kPa (100 cmH<sub>2</sub>O)
- Other interference factors

<b>Note</b>	<p>Accuracy is affected by the breath rate and I: E. The EtCO<sub>2</sub> accuracy is within specification for breath rate <math>\leq 60</math> rpm and I/E ratio <math>\leq 1:1</math>, or breath rate <math>\leq 30</math> rpm and I/E ratio <math>\leq 2:1</math>.</p>
-------------	---

## 3) AG Display

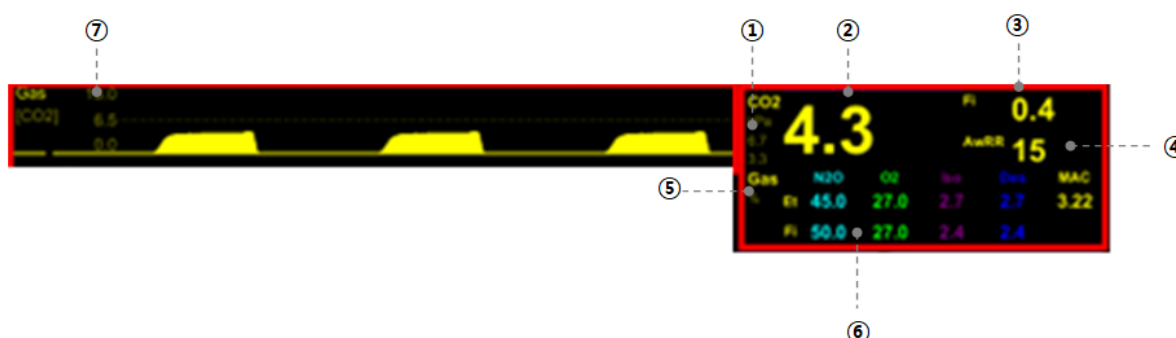

The AG module can send waveforms and numbers for all measured anesthetic gases to be displayed on the monitor, including:

- ① EtCO<sub>2</sub> unit and alarm high/low limit value

- ② End-tidal carbon dioxide concentration value
- ③ Intake carbon dioxide concentration value
- ④ Airway respiration rate
- ⑤ Unit of AA1
- ⑥ End tidal (Et) and fraction of inspired (Fi) numerics for N<sub>2</sub>O, O<sub>2</sub>, AA1, AA2 and MAC value
- ⑦ Gas waveform

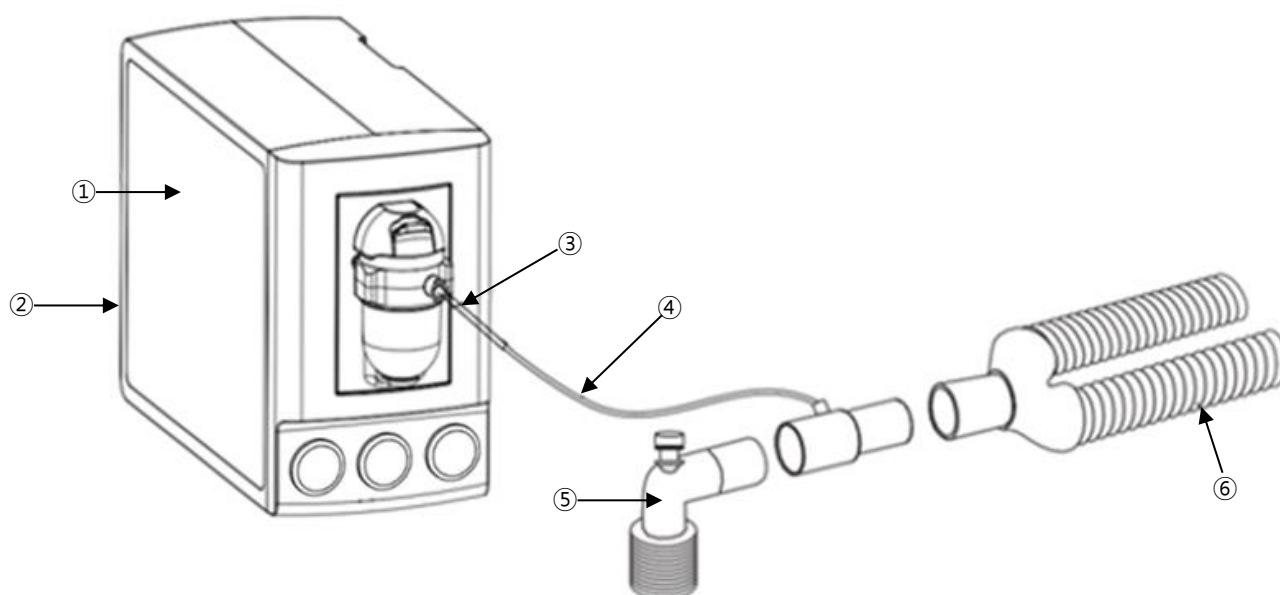

AA (Anesthetic Agent) indicates Des (desflurane), Iso (isoflurane), Enf (enflurane), Sev (sevflurane), or Hal (halothane).

#### 4) Connecting a Patient to AG Device



- ① AG module
- ② Gas outlet
- ③ Watertrap
- ④ Gas sample line
- ⑤ Airway adapter (connected to patient)
- ⑥ Y-piece (connected to the anesthesia machine)

**Accessory****Water trap**

Number	Part	Picture	Dimension	Weight
1	100-000080-00 / 115-058733-00		33mm(W) X 47mm(H) X 37mm(D)	10g
2	100-000081-00 / 115-058734-00		33mm(W) X 47mm(H) X 37mm(D)	10g

**샘플링 라인**

Number	Part	Picture	Dimension	Weight
1	60-15300-00 / 115-043018-00		small animal, 2.5m	13g
2	60-15200-00 / 115-043017-00		large animal, medium animal, 2.5m	17g

**Dryline Airway adapter**

Number	Part	Picture	Dimension	Weight
--------	------	---------	-----------	--------

1	60-14100-00 / 115-043020-00		Dryline airway adapter, straight	12g
2	60-14200-00 / 115-043021-00		Dryline airway adapter, elbow	15g

## 5) Preparing AG Monitoring

To prepare AG monitoring, perform the following:

1. Select the appropriate gas sample line and watertrap according to the patient's range.
2. Connect the watertrap to the AG module and connect the gas sample line to the watertrap.
3. Connect both ends of the gas sample line to the patient with an airway adapter.
4. Use an exhaust pipe to connect the gas outlet to the cleaning system or the patient's respiratory circuit.
5. Make sure they are all firmly connected.

### Warning

- When using the AG module, connect the gas outlet to the scavenging system or the patient respiration circuit when in use with the anesthesia machine.
- Please make sure that all connections are firm. Leakage of the system may cause ambient air to mix with the patient's gas and deteriorate the reading.
- Always check that the airway adapter is connected and operating properly before installing it in the patient.
- If you squeeze or bend the gas sample line during AG measurement, the reading may be incorrect or missing.
- The disposable airway adapters are designed for single use only and cannot be reused. Reuse may cause inaccurate readings, erratic readings,

	<p>or no readings at all. Also, reuse may cause an increased risk of cross contamination among patients.</p> <ul style="list-style-type: none"> <li>● The reusable airway adapters can be reused but to avoid infection, they shall be reused only after it is sterilized.</li> </ul>
--	---

Caution	<ul style="list-style-type: none"> <li>● Position the airway adapter so that the connection to the gas sample line is facing up. This prevents the condensed droplets from entering the gas sample line and causing obstruction.</li> <li>● The watertrap prevents the condensed droplets from collecting in the sample line and flowing into the module. Empty it when it is halfway full to prevent airway obstruction.</li> <li>● The watertrap has filters that prevent bacteria, water, and secretions from entering the module. If used for a prolonged time, dust or other substances can degrade the filter and block the airway. In this case, replace the watertrap. It is recommended changing the water bottle once a month.</li> </ul>
---------	---

Note	<ul style="list-style-type: none"> <li>● Do not apply large animal watertrap to small animals. Otherwise, the small animal may be injured.</li> <li>● To extend the life of the watertrap and module, if AG monitoring is not required, separate the watertrap from the module and set the action mode to standby mode.</li> </ul>
------	--

## 6) MAC value

Minimum alveolar concentration (MAC) is the minimum concentration of drugs in the alveoli. A basic indicator of the depth of anesthesia. Standard ISO 80601-2-55 defines MAC as follows: The alveolar concentration of inhaled anesthetics is no other anesthetic, and 50% of patients in equilibrium respond to standard surgical stimuli and become unable to move.

The MAC values are as follows.

Agent	Des	Iso	Enf	Sev	Hal	N <sub>2</sub> O
1 MAC	6%	1.15%	1.7%	2.1%	0.77%	105%*

\* 1 MAC nitrous oxide can only be reached in high-pressure chambers.

<b>Note</b>	<ul style="list-style-type: none"> <li>● The MAC values shown in the table above are published by the US Food and Drug Administration for healthy 40-year-old adult male patients.</li> <li>● In practical application, MAC values may be affected by age, weight, and other factors.</li> </ul>
-------------	--

The formula for calculating MAC values is as follows.

$$MAC = \sum_{i=0}^{N-1} \frac{EtAgent_i}{AgentVol_{age}^i}$$

Where N is the number of all agents (including N<sub>2</sub>O) that the AG module can measure. EtAgent<sub>i</sub> is the concentration of each agent, and AgentVol<sub>age</sub><sup>i</sup> is the concentration of each agent at 1 MAC with age correction. The formula for calculating age correction of 1 MAC is:

$$MAC_{age} = MAC_{40} \times 10^{(-0.00269 \times (age - 40))}$$

For example, the Des concentration at 1 MAC of a 60-year old patient is.

$$6\% \times 10^{(-0.00269 \times (60 - 40))} = 6\% \times 0.88$$

The AG module measures 4% of Des, 05% of Hal and 50% of N<sub>2</sub>O in the patient's end-tidal gas.

$$MAC = \frac{4.0\%}{6\% \times 0.88} + \frac{0.5\%}{0.77\% \times 0.88} + \frac{50\%}{105\% \times 0.88} = 2.04$$

<b>Note</b>	<b>Height, patient age, and other individual factors are not considered in the above formula.</b>
-------------	---

## 7) AG Setting Menu

When you select the AG numerical or waveform area, the setting menu appears.

Menu	Description	Available settings
<b>A. Alarm</b>	Anesthetic Gas (AG) alarm settings menu	EtCO <sub>2</sub> , FiCO <sub>2</sub> , AwRR, ZeroRR, EtN <sub>2</sub> O, FiN <sub>2</sub> O, EtO <sub>2</sub> , FiO <sub>2</sub> , EtAA1, EtAA1, ETAA2, EtAA2
<b>A-1. Alarm</b>	Set whether to detect an alarm.	On, Off
<b>A-2. Priority</b>	Set alarm priority	High, Medium, Low
<b>A-3. Low / High</b>	Set alarm low/high limit value.	
<b>A-4. Print</b>	Set print when an alarm occurs.	
<b>B Setup</b>	Setup menu	
<b>B-1. Speed</b>	Set waveform range speed.	6.25mm/s, 12.5mm/s, 25mm/s
<b>B-2. Size</b>	Set waveform size.  The values that can be selected are the maximum pressure range values shown as waveforms.  The size value set in the waveform area is displayed.	40, 50, 60, 80, 100, 150, 300, 500, 800, 1000 mmHg (5.0, 6.5, 8.0, 10.0, 13.0, 20.0, 40.0, 65.0, 100.0, 130.0 % , kpa)
<b>B-3 Wave Fill</b>	Select whether to fill in the waveform and draw it.	On / Off
<b>B-4 Waveform Type</b>	Set gas waveform to display.	CO <sub>2</sub> / O <sub>2</sub> / N <sub>2</sub> O / AG1 / AG2
<b>B-5 O<sub>2</sub> Display</b>	Set whether to mark O <sub>2</sub> .	On / Off
<b>B-6 Operating mode</b>	Set AG Module Mode. When it is not used, set Standby mode. If used, set Measurement mode.	Measure/ Standby
<b>B-7 Current Flow Rate</b>	Current flow rate display (ml/sec) Used for Anesthetic Gas (AG) leak	

---

	testing.	
--	----------	--

## 8) Making Changes in Anesthetic

If the anesthetic used in the patient changes, the AG module detects mixed anesthetic gas during the switching between the two anesthetics. The time required to complete the replacement depends on the anesthetic type (low or high flow) and the anesthetic characteristics (dynamic). The monitor does not display a prompt message between the two anesthetics, and the displayed MAC value may be incorrect.

The AG module can automatically identify two anesthetics. If the proportion of primary and secondary anesthetics in the mixture changes, the AG module can distinguish them according to their contribution to MAC values. Then the primary and secondary anesthetics is replaced for exhibition.

## 9) Performing AG Leakage Test

AG leakage test is required every time before AG measurement. To perform AG leakage test, follow the steps below.

1. Insert AG module into module rack.
2. Wait about 1 minute for AG module to be preheated. Please completely block the gas injection inlet of the AG module. Then, an alarm message saying, "**Airway Occluded**" appears on the screen.
3. Close the gas inlet for 1 minute.
4. Check the current flow rate by pressing the AG numerical area and select the Setup tab of the AG setting menu.
6. Check that the current flow rate is less than 10 ml/min and ensure that the "**Airway Occluded**" alarm message does not go away.

This indicates that the module is not leaking. If the alarm message disappears or the flow rate is more than 10ml/min, the module may leak. Please run the leak test again. If you encounter any problems, contact your service representative for help.

## 10) AG Module Calibration

Calibrate the AG module every year or automatically if the measurement is out of specification. Contact your service representative when modifying the AG module.

<b>Caution</b>	<ul style="list-style-type: none"> <li>● <b>Connect the gas outlet to the scavenging system when calibrating the AG module.</b></li> <li>● <b>The figures shown are invalidated within 30 seconds of the start of calibration/zero calibration.</b></li> </ul>
----------------	--

## 11) Troubleshooting

This section lists the problems that might occur. If you encounter the problems when using the monitor or accessories, check the table below before requesting service. If the problem persists, contact your service.

Problem	Solution
Airway blocked	<p><b>The Airway Occluded message appears. In this case, check the following until the message disappears.</b></p> <ol style="list-style-type: none"> <li>1) Check the airway adapter for obstruction and replace it if necessary.</li> <li>2) Check the sample line for blockages or kinks and replace it if necessary.</li> <li>3) Check the watertrap for water or blockages. Empty the watertrap or replace it if necessary.</li> <li>4) Check the gas outlet and exhaust tube for blockages.</li> </ol>

## PART 17. Printer

### 1) Overview

The printer mounted outside the monitor prints the observed results including trend and alarm data. Recording can be on-time or continuous and it is printed at the speed of 50 mm/s. Recordings are identified by the patient's name, ID as well as the date and time of the recording request. The monitor can automatically trigger alarm recordings for life-threatening alarms and limit violations if the Record function is enabled on the alarm limits table.

The thermal paper is used for printing. The size of the thermal paper roll is 58mm wide and 38mm in diameter. Any thermal paper of same dimension can be used with the printer.

<b>Caution</b>	<ul style="list-style-type: none"> <li>● <b>Connect the printer cable with the veterinary multiparameter monitor turned off.</b></li> <li>● <b>Due to the nature of thermal paper, heat is generated under continuous operation. It is recommended to let the printer cool down for 10 minutes after every five minutes of printing.</b></li> </ul>
----------------	---

### 2) Printer Setting Menu

When you select the Print Setup from the main menu, the setup menu appears.

<b>1. Speed</b>	Set print speed.	25 mm/s 50 mm/s
<b>2. Waveform1</b>	Set the first waveform.	Off, I / II/ III/ aVR/ aVL/ aVF/ V, SpO2, Resp, EtCO2, IBP1, IBP2, Gas(AG), IBP3, IBP4
<b>3. Waveform2</b>	Set the second waveform.	Same as above
<b>4. Waveform3</b>	Set the third waveform.	Same as above
<b>5. Print from Time</b>	Set the starting point of the data to be	Real time

	<p>printed.</p> <p>*Real Time: Data is printed from the time you press the Print menu.</p> <p>*Delay (5sec): Data from 5 seconds before you press the Print menu is printed.</p>	Delay (5sec)
6. Period	<p>Set print time.</p> <p>If you do not stop manually after pressing the Print menu, printing continues for the set time.</p>	Continue, 10sec, 20sec, 30sec

**Note**

The waveforms of IBP1, IBP2, IBP3, IBP4, Gas and ETCO2 on paper look different from the waveforms on screen. This is because the waveforms on paper can be scaled while the waveforms on screen cannot.

### 3) Storing the Thermal Paper

To avoid print quality degradation or attenuation of printouts, follow these precautions.

**Note**

These precautions apply to both unused paper as well as paper that has already ran through the printer.

- Store the paper in cool, dark locations. Temperature must be below 27°C (80°F). Relative humidity must be between 40% and 65%.
- Avoid exposure to bright light or ultraviolet sources such as sunlight, fluorescent, and similar lighting which causes yellowing of paper and fading of tracings.
- AVOID CONTACT WITH: cleaning fluids and solvents such as alcohols, ketones, esters, ether, etc.
- DO NOT STORE THERMAL PAPER WITH ANY OF THE FOLLOWING:
  - ✓ Carbon and carbonless forms.
  - ✓ Non-thermal chart papers or any other products containing tributyl phosphate, dibutyl

phthalate, or any other organic solvents. Many medical and industrial charts contain these chemicals.

- ✓ Document protectors, envelopes, and sheet separators containing polyvinyl chloride or other vinyl chlorides.
- DO NOT USE: mounting forms, pressure-sensitive tapes or labels containing solvent-based adhesives.

To assure maximum trace image life, thermal paper should be stored separately in: manilla folders, polyester, or polyimide protectors.

Plastic document protectors, envelopes, or sheet separators made of polystyrene, polypropylene, or polyethylene does not degrade thermal traces in themselves. However, these materials do not protect against fading from external causes.

Paper manufacturers advise us that these thermal products should retain their traces when properly imaged and stored for about 3-5 years.

If your retention requirements exceed these guidelines, we recommend you consider alternate image storage techniques.

## 4) Changing the Paper

1. Open the printer window.
2. Insert the paper roll offered with the monitor into the printing unit. Place the roll in a proper way so that the printed paper can roll out upwards.
3. Press the printer window until it is properly shut. Improper closure may cause failure in printing.

## 5) Troubleshooting

This section lists the problems that might occur. If you encounter the problems when using the monitor or accessories, check the table below before requesting service. If the problem persists, contact your service.

---

Problem	Solution
No printing	<ol style="list-style-type: none"><li data-bbox="571 304 1142 338">1 Check the printer module connection status.</li><li data-bbox="571 371 1139 405">2 Check that the tray cover is closed properly.</li><li data-bbox="571 439 1062 472">3 If there is no paper, put in new paper.</li><li data-bbox="571 506 1187 539">4 If the print side is reversed, turn the paper over.</li></ol>

## PART 18. Maintenance and Troubleshooting

### 1) Maintenance Safety Information

**Warning**

**Modifications to the veterinary multiparameter monitor are not permitted.**

**Caution**

- To avoid electric shock, if the housing is damaged, stop using the veterinary multiparameter monitor and contact your service representative.
- If the responsible individual hospital or institution neglects to follow the recommended maintenance schedule in the use of the veterinary multiparameter monitor, excessive equipment failure and health risks.
- The veterinary multiparameter monitor contains no user serviceable parts.
- Safety checks or maintenance related to disassembling the veterinary multiparameter monitor must be performed by qualified service representative. Failure to do so may result in excessive monitor failure or hazards to operators.
- Service representative should possess a working knowledge of the test tools and make sure that test equipment and cables are applicable.
- The battery and AC cords must be removed for repair.

### 2) Equipment Inspection

You should perform a visual Inspection before every use, and in accordance with your hospital's policy with the monitor switched off:

- Examine unit exteriors for cleanliness and general physical condition. Make sure the housings are not cracked or broken, everything is present, there are no spilled liquids, and there are no sign of abuse.
- If the EtCO<sub>2</sub> and Multi-gas module are mounted on the monitor, make sure that they are

locked into place and do not slide out without releasing the locking mechanism.

- Inspect all accessories (cables, transducers, sensors and etc.). If any show signs of damage, do not use.
- Switch the monitor on and make sure the backlight is bright enough. Check that screen is at its full brightness. If the brightness is not adequate, contact your service representative or your supplier.

**Warning**

**Using the veterinary multiparameter monitor adjacent to or stacked with other devices should be avoided because it could result in improper operation. If such use is necessary, the veterinary multiparameter monitor and the other devices should be observed to verify that they are operating normally.**

### 3) Cable Inspection

- Examine all system cables, the power plug for damage. Make sure that the prongs of the plug do not move in the adaptor. If damaged, replace it with an appropriate Bionet power cord and adaptor.
- Inspect the parameter cables and ensure that they make good connection with the monitor. Make sure that there are no breaks in the insulation.
- Apply the transducer or electrodes to the patient with the monitor switched on, and flex the patient cables near each end to make sure that there are no intermittent faults.

**Warning**

**To avoid contaminating or infecting personnel, the environment or other equipment, make sure to disinfect and decontaminate the veterinary multiparameter monitor appropriately before disposing of it in accordance with your country's laws for equipment containing electrical and electronic parts. For disposal of parts and accessories such as thermometers, where not otherwise specified, follow local regulations regarding disposal of hospital waste.**

## 4) Maintenance Tasks and Test Schedule

All maintenance tasks and performance tests are documented in detail in the service document.

Maintenance and test schedule	Frequency
Monitor tests	
Safety checks Selected tests on the basis of IEC 60601-1	At least once every two years, or as needed, after any repairs where the power supply is removed or replaced, or if the monitor has been dropped
Monitor maintenance	
Check ECG synchronization of the monitor and defibrillator (only if hospital protocol requires use of monitor during defibrillation).	At least once every two years, or as needed
Backlight replacement (integrated displays only).	35,000 - 40,000 hours (about four years) of continuous usage, or as needed
Parameter module tests	
Performance assurance for all measurements not listed below	At least once every two years, or if you suspect the measurement values are incorrect
Parameter module maintenance	
NIBP calibration	At least once every two years, or as specified by local laws
Mainstream and Sidestream CO2 calibration check	At least once a year, or if you suspect the measurement values are incorrect
Battery maintenance	
Battery	See the section on Maintaining Batteries in PART 1.

## 5) Troubleshooting

### In case of touchscreen malfunctions

Recalibrate the screen with the following steps.

1. Access the [Calibration] menu from the main menu, then select [Touch Screen Calibration].
2. Press the cross markers on the Touch Calibration Screen in chronological order.
3. Once the calibration is complete, the screen disappears.

**Caution**

**Do not use keys or menu navigation key (rotary knob) on the touch screen calibration screen.**

**Cyber security issues**

1. If equipment is stolen or lost, immediately report it to the hospital staff or manufacturer. When reported of a loss, the hospital network administrator must take measures to prevent the device from accessing hospital network.
2. If a cyber security threat is detected while using the equipment, immediately disconnect it from the network and contact the hospital staff or manufacturer.

※ For manufacturer contact information, please refer to the table of contents of How to contact us.

**Interruption of the supply mains exceeding 30 seconds**

1. Check that the visual and auditory alarm signals are presented correctly when the monitor is powered on.
2. Operate the monitor on battery power if the integrity of the protective earth conductor or the protective earthing system in the installation is in doubt.
3. If the power supply is cut off for more than 30 seconds, it returns to the default setting of the manufacturer, restores the default setting of the responsible authority, and returns to the last setting used.

**If the device's time does not match the current time**

Enter the current time in the System Setup > Date Time menu of the main menu and apply it. (Refer to F-3. Date Time in Chapter 2 Main Menu)

---

## PART 19. Cleaning and Care

### 1) Overview

Clean the monitor and accessories daily or after each patient use according to your hospital's standard protocol or procedures below.

Bionet does not claim the right to the following chemical efficacy, disinfectant method, the ability of the drug to inhibit bacterial infection, environmental impact, safe handling or precautions related to use. For more information on these topics, see the information provided by the detergent manufacturer.

### 2) Monitor and Accessories

Moisture can damage the monitor and accessories. (For example, around connectors or EtCO<sub>2</sub> modules).

Please read the following instructions carefully before cleaning the monitor or accessories.

- Do not sterilize by autoclaving, pressure sterilization or gas sterilization.
- Do not spray any cleaning solution on the monitor or accessories. Excessive use of cleaning liquid may flow into the monitor and cause damage to internal components.
- Wipe off the cleaning solution with a damp cloth.
- Disinfect the surface with diluted alcohol gauze.
- Do not use petroleum/acetone cleaning solutions or other strong solvents to clean the monitor or accessories. These substances may damage the device and cause the device to malfunction.
- Wipe clean with a lint-free cloth.
- Do not touch, press, or rub the display panel with abrasive tools, brushes, or rough surfaces. Also, don't come close to anything that could scratch the panel.
- Do not spray detergent on the monitor or peripheral devices. Wipe it off with a damp cloth.

<b>Caution</b>	<ul style="list-style-type: none"><li>● <b>Do not wet or rinse the veterinary multiparameter monitor and accessories. Disconnect the monitor from the power source if you accidentally spilled liquid on it. Contact your technician for stability before operating the veterinary multiparameter monitor.</b></li><li>● <b>To prevent damage to the veterinary multiparameter monitor, do not use sharp tools or abrasives. Never leave the electrical connector soaked in water or other liquids. When cleaning, be careful not to let the liquid stick to the edge of the screen.</b></li></ul>
----------------	--

### All Patient Cables

- Clean the patient cables with a gauze pad moistened with a soap solution.
- To disinfect patient cables, wipe the cables with a gauze moistened with diluted alcohol or a glutaraldehyde-based disinfectant.
- Ethylene oxide is suitable for intensive disinfection (almost sterilization), but it shows that the service life of cables and lead wires is reduced.
- Dry thoroughly with a lint-free cloth.

All patient cables can be wiped or cleaned with a warm, damp towel, mild soap, or isopropyl alcohol. Disinfect all patient cables with gauze moistened with diluted alcohol.

<b>Caution</b>	<ul style="list-style-type: none"><li>● <b>Do not use disinfectants that contain phenol as they can spot plastics. Do not autoclave or clean the accessories with strong aromatic, chlorinated, ketone, ether, or ester solvents. Never have the electrical connectors soaked.</b></li><li>● <b>When cleaning, do not apply excessive pressure or bend the cable unnecessarily. Excessive pressure can damage the cables.</b></li></ul>
----------------	---

### Reusable ECG Electrodes

Clean the electrode cup regularly with a toothbrush. When removing gel-like residues, use a soft brush with flowing water. Wipe the electrode with a soapy cloth moistened with soapy water.

- Sterilize the electrodes by soaking the diluted alcohol in cloth.

- Dry thoroughly with a lint-free cloth.

### Reusable SpO2 sensor

Use clean SpO2 sensor by wiping it with soapy water gauze. Disinfect the sensor by wiping with 70% alcohol solution. Allow the sensor to dry completely with a lint-free cloth before applying to the patient.

### Reusable Temperature Probe and Cables

Do not use excessive pressure or flex the cables as this can stretch the covering and break the internal wires.

- Clean the Probe with a 3% hydrogen peroxide or 70% alcohol.
- Quickly soak the cables in a detergent solution.
- Make sure the tip of the probe is firmly connected.

### Capnostat Sensor

Wipe the sensor surface and sensor window with a damp cloth. Do not attempt to wet the sensor or disinfect it with hot water. Allow to dry completely with a lint-free cloth. Make sure the sensor window is clean and dry before use.

### IBP Transducer

Handle transducers and other pressure accessories with care. Do not apply excessive pressure to the conversion board. Do not expose the transducer to water, steam, dry heat sterilization, ether, chloroform, or other similar chemicals. Always protect the connector from water.

#### Warning

- **For more information on cleaning, disinfecting, and sanitizing reusable accessories, refer to the accessory manufacturer's instructions for use.**
- **Do not reuse disposable accessories.**

<b>Warning</b>	<b>Never boil or autoclave the cables. Vinyl withstands temperatures up to 100°C but begins to soften at around 90°C. Handle gently when hot and wipe away from the tip toward the cables.</b>
----------------	--

<b>Caution</b>	<b>Decisions on disinfection should be made by your organization in accordance with the integrity of the wires or lead wires.</b>
----------------	---

<b>Note</b>	<b>The veterinary multiparameter monitor should be inspected regularly once a year. For Inspection items, refer to this operation manual or service manual.</b>
-------------	---

Carefully inspect the monitor and sensor after cleaning the monitor. Do not use damaged or old monitor.

Clean the exterior of the monitor at least once a month using a soft cloth moistened with lukewarm water or alcohol. Do not use lacquer, thinners, ethylene, or oxidizers that could damage the monitor.

Make sure that the cables and accessories are free from dust and dirt. Then wipe them with a soft cloth moistened with 40°C water. Please wipe it with clinical alcohol at least once a week.

Do not soak the accessories in liquid or detergent. Also, prevent any fluid from seeping into the monitor or probe.

<b>Caution</b>	<ul style="list-style-type: none"><li>● <b>Do not dispose of the disposable probe in a potentially hazardous area.</b></li><li>● <b>Always be careful about environmental pollution.</b></li></ul>
----------------	--

<b>Caution</b>	<ul style="list-style-type: none"><li>● <b>There is a backup battery inside the system.</b></li><li>● <b>When disposing of the battery, dispose of it in an appropriate place to protect the environment.</b></li></ul>
----------------	---

---

**Warning** When replacing the backup battery, check the battery electrode.

If you suspect the installation or disposition of the external ground wire, operate the monitor by means of the internal power supply.

If the monitor is not used for a certain period, remove the backup battery to avoid any safety hazard.

## PART 20. Technical Specifications

### 1) Overview

The veterinary multiparameter monitor is not user installable. Qualified service representative must install it.

The veterinary multiparameter monitor is intended to be used for monitoring, recording, and alarming of multiple physiological parameters of large animals and small animals in health care facilities. The monitor is to be used by trained health care professionals.

The veterinary multiparameter monitor is intended for use in health care facilities.

### 2) EMC Compatibility (EMC)

Much of the information below has been borrowed from the requirements set forth in the Electromagnetic Compatibility Standard IEC 60601-1-2 for medical electrical equipment issued by the International Electro technical Commission and is available from a variety of sources. Although primarily aimed at equipment manufacturers, most of the information contained here is useful for users interested in medical equipment.

The information contained in this section (such as separation distance) are general information about the Bionet's veterinary multiparameter monitor. The numbers provided here are not guaranteed but are provided with reasonable assurance of error-free operation. This information may not apply to other medical and electrical systems, and older equipment may be particularly susceptible to interference.

<b>Warning</b>	<b>Low amplitude signals such as ECG are particularly sensitive to interference from electromagnetic energy. The veterinary multiparameter monitor complies with the tests listed at the bottom but does not guarantee complete operation. The "quiet" electrical environment is better. In general, the greater the distance between electrical equipment, the lower the likelihood of interference.</b>
<b>Note</b>	<b>Medical electrical equipment requires special precautions for electromagnetic compatibility and must be installed and serviced in accordance with the EMC information in this section and in the operating instructions supplied with the</b>

**veterinary multiparameter monitor.**

**Portable and mobile RF communication equipment can affect medical electrical equipment.**

**Cables and accessories not specified in this manual are not certified. Using other cables and / or accessories may adversely affect safety, performance, and electromagnetic compatibility (increased electromagnetic emissions and reduced immunity).**

- **Use of this veterinary multiparameter monitor adjacent to or stacked with other devices should be avoided because it could result in improper operation. If such use is necessary, this monitor and the other equipment should be observed to verify that they are operating normally.**
- **The veterinary multiparameter monitor communicates over a 2.4 GHz 80211b / g wireless network. Other equipment may interfere with data reception on this wireless network. This is also true if the equipment complies with the CISPR emission requirements. When using the veterinary multiparameter monitor to communicate over a wireless network, be sure to check that it is compatible with existing or new wireless systems (e.g., cell phones, pager systems, cordless phones, etc.). For example, a Bluetooth-compliant device using the 2.4 GHz frequency band may interfere with the wireless communication of the veterinary multiparameter monitor. For more information on wireless deployment, please contact your Bionet representative.**

### 3) Manufacturer's Declaration - Electromagnetic Emission

**The veterinary multiparameter monitor are intended for use in the electromagnetic environment specified below. The customer or the user of the veterinary multiparameter monitor system must ensure that it is used in such as environment.**

Emission test	Compliance	Electromagnetic environment - guidance
---------------	------------	--

Mains terminal disturbance voltage CISPR 11	GROUP1, CLASS A	The EMISSIONS characteristics of the veterinary multiparameter monitor make it suitable for use in industrial areas and hospitals (CISPR 11 class A). If it is used in a residential environment (for which CISPR 11 class B is normally required) The veterinary multiparameter monitor might not offer adequate protection to radio-frequency communication services. The user might need to take mitigation measures, such as relocating or re-orienting the equipment.
RADIATED DISTURBANCE CISPR 11	GROUP1, CLASS A	
Harmonic Current Emission IEC 61000-3-2	CLASS A	The veterinary multiparameter monitor are suitable for use in all establishments other than domestic, and may be used in domestic establishments and those directly connected to the public low-voltage power supply network that supplies buildings used for domestic purposes, provided the following warning is heeded:  Warning: This equipment/system is intended for use by healthcare professionals only.  This equipment/ system may cause radio interference or may disrupt the operation of nearby equipment. It may be necessary to take mitigation measures, such as re-orienting or relocating the Veterinary multiparameter monitor or shielding the location.
Voltage fluctuations/Flicker IEC 61000-3-3	Complies	

#### 4) Manufacturer's Declaration - Electromagnetic Immunity

The veterinary multiparameter monitor system are designed for use in the electromagnetic environment specified below. The customer or the user of the Veterinary multiparameter monitor system must ensure that it is used in such an environment.			
Immunity test	IEC 60601 Test level	Compliance level	Electromagnetic Environment - guidance
Electrostatic Discharge Immunity (ESD) IEC 61000-4-2	±8 kV/Contact ±2, ±4, ±8, ±15 kV/Air	±8 kV/Contact ±2, ±4, ±8, ±15 kV/Air	Floors should be wood, concrete or ceramic tile. If floors are covered with synthetic material, the relative humidity should be at least 30%.
Radiated RF Electromagnetic Field Immunity IEC 61000-4-3	3 V/m 80 MHz - 2.7 GHz 80% AM at 1 kHz	3 V/m 80 MHz - 2.7 GHz 80% AM at 1 kHz	The veterinary multiparameter monitor are suitable to use in professional healthcare environment.
Immunity to Proximity Fields from RF wireless Communication s Equipment IEC 61000-4-3	28 V/m Max. 385-5785 MHz in according to table 9 in IEC 60601-1-2	28 V/m Max. 385-5785 MHz in according to table 9 in IEC 60601-1-2	RF communication equipment is used no closer than 30 cm to any part of the veterinary multiparameter monitor including cables specified by Bionet.

Electrical Fast Transient/Burst Immunity IEC 61000-4-4	$\pm 2$ kV, 100 kHz repetition frequency	$\pm 2$ kV, 100 kHz repetition frequency	The quality of supplied power should be suitable for general business site or hospital environment.
Surge Immunity IEC 61000-4-5	Line to Line $\pm 0.5$ kV, $\pm 1$ kV  Line to Ground $\pm 0.5$ kV, $\pm 1$ kV, $\pm 2$ kV	Line to Line $\pm 0.5$ kV, $\pm 1$ kV  Line to Ground $\pm 0.5$ kV, $\pm 1$ kV, $\pm 2$ kV	The quality of supplied power should be suitable for general business site or hospital environment.
Immunity to Conducted Disturbances Induced by RF fields IEC 61000-4-6	3 V 0.15 MHz - 80 MHz  6 V in ISM bands between 0.15 MHz and 80 MHz  80% AM at 1 kHz	3 V 0.15 MHz - 80 MHz  6 V in ISM bands between 0.15 MHz and 80 MHz  80% AM at 1 kHz	The strength of RF field in the frequency range higher than 150 kHz~80 MHz, the strength of the RF field is smaller than 3 V.
Power Frequency Magnetic Field Immunity IEC 61000-4-8	30 A/m 50 & 60 Hz	30 A/m 50 & 60 Hz	Power frequency magnetic fields should be at levels characteristic of a typical location in a typical commercial or hospital environment.

<p>Voltage dips IEC 61000-4-11</p>	<p>0% <math>U_T</math>: 0.5 cycle At 0°, 45°, 90°, 135°, 180°, 225°, 270° and 315°</p> <p>0% <math>U_T</math>; 1 cycle and 70% <math>U_T</math>; 30 cycles Single phase: at 0°</p>	<p>0% <math>U_T</math>: 0.5 cycle At 0°, 45°, 90°, 135°, 180°, 225°, 270° and 315°</p> <p>0% <math>U_T</math>: 1 cycle and 70 % <math>U_T</math>; 30 cycles Single phase: at 0°</p>	<p>Mains power quality should be that of a typical commercial or hospital environment. If the user of the veterinary multiparameter monitor requires continued operation during power mains interruptions, it is recommended that the veterinary multiparameter monitor be powered from an uninterruptible power supply, or a battery be used with the system power source.</p>
------------------------------------	--	---	---

Voltage interruptions IEC 61000-4-11:	0% U <sub>T</sub> : 250/300 cycles	0% U <sub>T</sub> : 250/300 cycles	<p>The veterinary multiparameter monitor are suitable to use in professional healthcare environment.</p> <p>Portable radio frequency (RF, RFID) communication devices can interfere with the medical electrical device. Therefore, do not use your mobile phone in a medical office or hospital environment.</p>
---------------------------------------	------------------------------------	------------------------------------	--

<p>Radiated fields in close proximity IEC 61000-4-39</p>	<p>65 A/m Max 30 kHz - 13.56 MHz in according to table 11 in IEC 60601-1-2</p>	<p>65 A/m Max 30 kHz - 13.56 MHz in according to table 11 in IEC 60601-1-2</p>	<p>The veterinary multiparameter monitor are suitable to use in professional healthcare environment.</p> <p>Portable radio frequency (RF, RFID) communication devices can interfere with the medical electrical device. Therefore, do not use your mobile phone in a medical office or hospital environment.</p>
<p><b>Note</b> <math>U_T</math> is the AC mains voltage prior to application of the test level.</p>			

<p><b>Note</b></p>	<ul style="list-style-type: none"> <li>● For Type A Professional ME Equipment intended for use in domestic establishment instructions for use includes a warning.</li> <li>● This ME equipment is intended for use by professional healthcare personnel only.</li> </ul>
--------------------	--

<p><b>Warning</b></p>	<p>Portable RF communications equipment (including peripherals such as antenna cables and external antennas) should be used no closer than 30 cm (12 inches) to any part of the [ME EQUIPMENT or ME SYSTEM], including cables specified by the manufacturer.</p>
-----------------------	--

**Warning**

Using accessories and cables other than those specified or provided by the manufacturer of the veterinary multiparameter monitor could result in increased electromagnetic emissions or decreased electromagnetic immunity of the veterinary multiparameter monitor and result in improper operation.

## 5) System Specifications

Physical				
Model	Brio X3VET	Brio X5VET	Brio X7VET	
<b>Dimension (HxWxD) (mm)</b>	237 x 221 x 136.5	308 x 273 x 140	394 x 305 x 157	
<b>Weight (Kg)</b>	Approx. 2.0	Approx. 3.1	Approx. 4.1	
<b>Cooling</b>	Air flow			
<b>Power</b>	AC power (100-240VAC, 1.5~0.75A, 50/60Hz)			
<b>Power consumption</b>	< 25 Watts	< 35 Watts		
<b>Operating Mode</b>	Continuous			
<b>Display</b>	<b>Type</b>	TFT-LCD		
	<b>Resolution</b>	1024 x 600	1280 x 800	1366 x 768
	<b>Size</b>	8"	12.1"	15.6"
<b>Measurement Parameter</b>	<b>Common</b>	ECG, heart rate, respiration rate, EtCO <sub>2</sub> , FiCO <sub>2</sub> , airway respiration rate, temperature x2, IBP x2 SpO <sub>2</sub> , pulse rate, systolic BP, diastolic BP, mean BP		
	<b>Option</b>	AG(Dual Gas)	IBP x 2, AG(ParaMount), AG(Dual Gas)	
<b>TRACE</b>	<b>Waveforms</b>	5 waveforms: ECG, SpO <sub>2</sub> , RR or EtCO <sub>2</sub> or AG, IBP x 2	7 Waves: ECG, SpO <sub>2</sub> , RR or EtCO <sub>2</sub> or AG, IBP x 4	
	<b>Sweep Speed</b>	Sweep speed: 6.25, 12.5, 25, 50 mm/sec		

<b>Indicator</b>	(Based on alarm type and priority) 3-color visual alarm lamp, SpO2 pulse pitch tone, Battery status, External power LED	
<b>Interface</b>	AC input connector LAN port for transferring data HDMI output connector USB connector Printer module connector Paramount module connector (Brio X5VET, Brio X7VET only)	
<b>Battery</b>	Rechargeable Li-ion battery	
<b>Degree of protection against harmful ingress of water</b>	IPX2	
<b>Thermal Printer (option)</b>	Speed: 50mm/sec, Paper width: 58mm	
<b>Data Storage</b>	<b>Common</b>	168 hours trends data
	<b>Option</b>	1000 alarm events (all numbers and waveforms for a total of 16 seconds, 8 seconds before and after the event)
<b>Language</b>	English, Korean, French, Polish, German, Chinese, Portuguese, Hungarian, Czech, Romanian, Italian, Turkish, Spanish, Russian, Japanese, Dutch	
<b>Environments</b>		
<b>Temperature</b>	Operating: 5 ~ +40 °C (41 ~ 104 °F) Storage: -20 ~ +60 °C (-4 ~ +140 °F)	
<b>Humidity</b>	Operating: 30% ~ 85%, Storage: 10% ~ 95% (Package)	
<b>Operating Altitude</b>	Operating: 525 ~ 795 mmHg (70 ~ 106 kPa) Storage: 375 ~ 795 mmHg (50 ~ 106 kPa)	

<b>ECG Specification</b>		
<b>Method</b>	meets the requirements of IEC 60601-2-27: 2011 and IEC 60601-2-25: 2011	
<b>Lead Type</b>	3-Lead 5-Lead	

<b>Lead Selection</b>	3-Lead: I, II, III 5-Lead: I, II, III, aVR, aVL, aVF, V
<b>ECG waveforms</b>	3-Lead: 1 channel 5-Lead: 2/7 channel
<b>Heart Rate Range</b>	15 ~ 350 bpm
<b>Heart Rate Accuracy</b>	$\pm 1$ bpm or $\pm 1\%$ , whichever is greater
<b>Sweep Speed</b>	6.25, 12.5, 25, 50 mm/sec
<b>Filter</b>	Diagnosis : 0.05 ~150 Hz Monitoring : 0.5 ~40 Hz Surgery : 1 ~ 25 Hz Maximum : 5 ~ 25 Hz
<b>ST Segment Detection Range</b>	-2.0 to 2.0 mV
<b>Arrhythmia Analysis</b>	Asystole, V-Tach, V-Tach/V-Fib, Bigeminy, Trigeminy, Acc Vent Couplet, Irregular, Pause, R on T, V-Brady, Short Run, PVC
<b>Protection</b>	Against electrosurgical interference and defibrillation
<b>Pace pulse rejection</b>	When tested in accordance with the IEC 60601-2-27: 2011: 201.12.1.101.13, the heart rate meter rejects all pulses meeting the following conditions.  Amplitude: $\pm 2$ mV to $\pm 700$ mV Width: 0.1 ms to 2 ms Rise time: 10 $\mu$ s to 100 $\mu$ s (< 10% of pulse width) No overshoot
<b>Response to irregular rhythm</b>	In compliance with the requirements in Clause 201.7.9.2.9.101 b) 4) of IEC 60601-2-27: 2011, the heart rates for the specified test signals after 20 seconds of stabilization are: Ventricular bigeminy (waveform A1): $80 \pm 1$ bpm Slow alternating ventricular bigeminy (waveform A2): $60 \pm 1$ bpm Rapid alternating ventricular bigeminy (waveform A3): $120 \pm 1$ bpm

	Bidirectional systoles (waveform A4): $90 \pm 2$ bpm	
<b>Time to alarm for tachycardia</b>	1) waveform B1:	
	Amplitude	Time to alarm
	0.5 mV (1/2)	Fail – 0 bpm
	1 mV	7 sec
	2 mV (2)	4 sec
	2) waveform B2:	
	Amplitude	Time to alarm
	1 mV (1/2)	Fail – under 60 bpm
	2 mV	2 sec
	4 mV (2)	2 sec
<b>Respiration</b>	Sensing leads	I, II (user-selectable)
	Measuring method	Impedance pneumography
	Auxiliary current	$\leq 10\mu\text{A}$ for any active electrode
	Detection threshold	1.0 $\Omega$ To 3.0 $\Omega$
	Measuring range	5 to 120 breaths per min
	Accuracy	$\pm 1$ breath/min or 2% of rate
	Apnea detection	For all patients
	Alarms	User-selectable upper/lower respiration rate

Respiration Specifications	
<b>Method</b>	Thoracic impedance
<b>Channel Selection</b>	RA-LL / RA-LA
<b>Measurement Range</b>	5 ~ 120 breaths per minute
<b>Accuracy</b>	$\pm 1$ breath per minute
<b>Apnea Alarm</b>	Yes

SpO2 Specifications	
<b>SpO2 Range</b>	0 ~ 100%

<b>SpO2 Accuracy</b> *The specified accuracy is the root-mean-square (RMS) difference between the measured values and the reference values.	70 ~ 100%: $\pm 2$ digits 0 ~ 69%: unspecified
<b>Pulse Rate Range</b>	18 ~ 450 bpm
<b>Pulse Rate Accuracy</b>	$\pm 2$ bpm
<p><b>Test methods used in 2012.12.101.2 to establish SpO2 accuracy claims</b></p> <ol style="list-style-type: none"> <li>1. Connect the SpO2 sensor to the SpO2 connector on the monitor. Set patient category as adult and PR source. Go to SpO2.</li> <li>2. Apply the SpO2 sensor to the ring finger of a healthy person.</li> <li>3. Check the PLT waves and PR readings on the screen and ensure that the SpO2 shown is measured within the error range.</li> <li>4. Remove the SpO2 sensor from the finger and verify that the SpO2 Sensor Off alarm is triggered.</li> </ol> <p>Verification of measurement accuracy: SpO2 accuracy was confirmed in human experiments compared to arteries. Based on blood samples measured by CO-oximeter. Pulse oximeter measurements are made statistically. Approximately two-thirds of the measurements must be within the specified accuracy range. Compared to the CO-oximeter measurement.</p>	

<b>NIBP Specifications</b>	
<b>Standard</b>	Meets the requirements of ISO 80601-2-30: 2018
<b>Method</b>	Oscillometry with step deflation
<b>Operation Mode</b>	Manual/Automatic
<b>Measurement Range</b>	Systolic : 40 ~ 260 mmHg MAP : 26 ~ 220 mmHg Diastolic : 20 ~ 200 mmHg

<b>Accuracy</b>	Mean error: less than $\pm 5$ mmHg Standard deviation: less than 8 mmHg
-----------------	--

<b>Temperature Specification</b>	
<b>Standard</b>	Meets the requirements of ISO 80601-2-56: 2018
<b>Method</b>	Thermal resistance
<b>Operation mode</b>	Direct mode
<b>Measurement Range</b>	0 ~ 50°C (32 ~ 122°F)
<b>Accuracy</b>	25 ~ 45°C: $\pm 0.1^\circ\text{C}$ Below 25°C, above 45°C: $\pm 0.2^\circ\text{C}$
<b>Compatibility</b>	98ME04GA603 temperature probes

<b>Sidestream CO2 (Option)</b>	
<b>Standard</b>	meets the requirements of ISO 80601-2-55: 2018
<b>Warm-up time</b>	Full specifications within 2 minutes at an ambient temperature of 25° C. Capnogram in 15 seconds
<b>Measurement Range</b>	0 ~ 150 mmHg, 0 ~ 19%
<b>Accuracy</b> (at 760 mmHg, ambient temperature of 25°C)	0 ~ 40mmHg $\pm 2$ mmHg, 41 ~ 70mmHg $\pm 5\%$ of reading 71 ~ 100mmHg $\pm 8\%$ of reading, 101 ~ 150mmHg $\pm 10\%$ of reading  (At respiration rates > 80 breaths per minute, all ranges are $\pm 12\%$ of actual.)
<b>Respiration Rate</b>	2 ~ 150 breaths per minute
<b>Respiration Accuracy</b>	$\pm 1$ breath per minute
<b>Rise Time</b>	< 3 seconds (includes transport and rise time)
<b>Sample Flow Rate</b>	50 ml/min $\pm 10$ ml/min
<b>Data sample rate</b>	100 Hz

**The test method used to determine the RATED respiration rate range and the corresponding effects of end-tidal GAS READING accuracy as a function of respiratory rate as required in 201.7.9.2.9 i) and j)**

The method consists of sampling gas from two different sources connected to an electrically controlled pneumatic valve to permit rapid switching between the two sources.

During the test, the valve is set to switch gas source at several frequencies (simulating the range of specified breath rates) and for each frequency the end-tidal value presented by the CAPNOSTAT is noted.

From a diagram of end-tidal value over frequency, the frequency at which the gas analyzer is no longer able to resolve end-tidal values according to specification is identified.

**The method used to calculate end-tidal GAS READINGS**

Inspiratory and end tidal CO<sub>2</sub> concentration readings are identified by CAPNOSTAT sensor using the lowest and highest values respectively of the temporal CO<sub>2</sub>-curve.

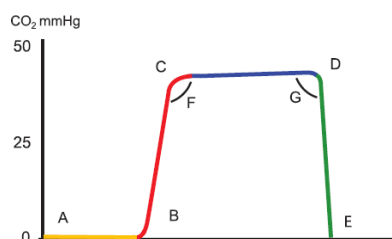

**Phase I:** A-B End of inspiratory phase and start of exhalation. Represents anatomical dead space with no measurable CO<sub>2</sub>.

**Phase II:** B-C Early exhalation. Rapid rise in CO<sub>2</sub> concentration as anatomical dead space is replaced with alveolar gas.

**Phase III:** C-D Alveolar Plateau. Corresponds to alveolar emptying. In the normal capnogram the alveolar plateau has a slight rise. The end of the alveolar plateau corresponds to the ET-CO<sub>2</sub> (D).

**Phase IV:** D-E Inspiration begins. Rapid downward stroke corresponds to the fresh gas which is essentially free of carbon dioxide. The capnograph falls to zero and then remains at zero baseline throughout inspiration.

**Mainstream CO<sub>2</sub> (Option)**

**Standard**

Meets the requirements of ISO 80601-2-55: 2018

<b>Warm-up time</b>	Full specifications within 2 minutes at an ambient temperature of 25° C. Capnogram in 15 seconds
<b>Measurement Range</b>	0 ~ 150 mmHg, 0 to 19%
<b>Accuracy</b> (at 760 mmHg, ambient temperature of 25°C)	0 ~ 40mmHg $\pm 2$ mmHg, 41 ~ 70mmHg $\pm 5\%$ of reading 71 ~ 100mmHg $\pm 8\%$ of reading, 101 ~ 150mmHg $\pm 10\%$ of reading  (At respiration rates > 80 breaths per minute, all ranges are $\pm 12\%$ of actual.)
<b>Respiration Rate</b>	2 ~ 150 breaths per minute
<b>Respiration Accuracy</b>	$\pm 1$ breath per minute
<b>Rise Time</b>	< 60 ms (Adult/pediatric adapters) < 60 ms (Infant/pediatric adapters)
<b>Data sample rate</b>	100 Hz
<p><b>The test method used to determine the RATED respiration rate range and the corresponding effects of end-tidal GAS READING accuracy as a function of respiratory rate as required in 201.7.9.2.9 i) and j)</b></p> <p>The method consists of sampling gas from two different sources connected to an electrically controlled pneumatic valve to permit rapid switching between the two sources.</p> <p>During the test, the valve is set to switch gas source at several frequencies (simulating the range of specified breath rates) and for each frequency the end-tidal value presented by the CAPNOSTAT is noted.</p> <p>From a diagram of end-tidal value over frequency, the frequency at which the gas analyzer is no longer able to resolve end-tidal values according to specification is identified.</p>	
<p><b>The method used to calculate end-tidal GAS READINGS</b></p> <p>Inspiratory and end tidal CO<sub>2</sub> concentration readings are identified by CAPNOSTAT sensor using the lowest and highest values respectively of the temporal CO<sub>2</sub>-curve.</p>	

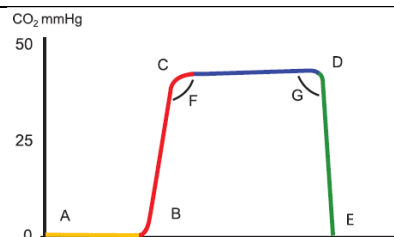

**Phase I:** A-B End of inspiratory phase and start of exhalation. Represents anatomical dead space with no measurable CO<sub>2</sub>.

**Phase II:** B-C Early exhalation. Rapid rise in CO<sub>2</sub> concentration as anatomical dead space is replaced with alveolar gas.

**Phase III:** C-D Alveolar Plateau. Corresponds to alveolar emptying. In the normal capnogram the alveolar plateau has a slight rise. The end of the alveolar plateau corresponds to the ETCO<sub>2</sub> (D).

**Phase IV:** D-E Inspiration begins. Rapid downward stroke corresponds to the fresh gas which is essentially free of carbon dioxide. The capnograph falls to zero and then remains at zero baseline throughout inspiration.

IBP Specifications	
<b>Standard</b>	Meets the requirements of IEC 60601-2-34: 2011
<b>Channels</b>	Brio X3VET : 2 ch Brio X5VET, Brio X7VET : 4 ch
<b>Measurement Range</b>	-50 ~ 300mmHg
<b>Accuracy</b>	±4 % of reading or ± 4 mmHg, whichever is greater
<b>Pulse Rate Measurement Range</b>	20 ~ 300bpm
<b>Zero Balancing</b>	Range: ±200mmHg Accuracy: ±1mmHg Drift: ±1mmHg over 24hours
<b>Transducer Sensitivity</b>	5µV/V/mmHg

Anesthetic Gas(AG) – ParaMount module Specifications (Option / Brio X5VET, Brio X7VET only)	
<b>Standard</b>	Meets the requirements of ISO 80601-2-55: 2018
<b>Technique</b>	Infrared absorption, paramagnetic properties for O <sub>2</sub> monitoring
<b>Warm-up time</b>	≤10 min
<b>Sample flow rate</b>	Adult, pediatric: 200 ml/min Neonate: 120 ml/min Accuracy: ±10 ml/min or ±10%, whichever is greater
<b>Measurement range</b>	CO <sub>2</sub> : 0 to 30% O <sub>2</sub> : 0 to 100% N <sub>2</sub> O: 0 to 100% Des: 0 to 30% Sev: 0 to 30% Enf: 0 to 30% Iso: 0 to 30% Hal: 0 to 30% awRR: 2 to 100 rpm

---

<b>Resolution</b>	CO <sub>2</sub> :	0.1%
	O <sub>2</sub> :	1%
	N <sub>2</sub> O:	1%
	Des:	0.1%
	Sev:	0.1%
	Enf:	0.1%
	Iso:	0.1%
	Hal:	0.1%
	awRR:	1 rpm

Full accuracy	Gases	Range (%REL) <sup>1</sup>	Accuracy (%ABS)
	CO <sub>2</sub>	0 ≤ CO <sub>2</sub> ≤ 1	±0.1
		1 < CO <sub>2</sub> ≤ 5	±0.2
		5 < CO <sub>2</sub> ≤ 7	±0.3
		7 < CO <sub>2</sub> ≤ 10	±0.5
		CO <sub>2</sub> > 10	Not specified
	N <sub>2</sub> O	0 ≤ N <sub>2</sub> O ≤ 20	±2
		20 < CO <sub>2</sub> ≤ 100	±3
	O <sub>2</sub>	0 to 25	±1
25 to 80		±2	
80 to 100		±3	
Des	0 to 1	±0.15	
	1 to 5	±0.2	
	5 to 10	±0.4	
	10 to 15	±0.6	
	15 to 18	±1	
	> 18	Not specified	
Sev	0 to 1	±0.15	
	1 to 5	±0.2	
	5 to 8	±0.4	
	> 8	Not specified	
Enf, Iso, Hal	0 to 1	±0.15	
	1 to 5	±0.2	
	> 5	Not specified	
awRR	2 to 60 rpm	±1 rpm	
	> 60 rpm	Not specified	
Note1: The highest GAS LEVEL for a single halogenated anesthetic gas in a gas mixture that is concealed when the anesthetic concentration falls is 0.15/0.3% (Full/ISO accuracy)			
Accuracy drift	Meets the requirement for measurement accuracy within 6 hours		
Zero RR alarm delay	10 s, 15 s, 20 s, 25 s, 30 s, 35 s, 40 s		
Refresh rate	1 s		
Rise time (10% ~	Gas sample flow rate 120ml/min, using a DRYLINE II neonatal watertrap and sampling line (2.5m):		

<b>90%)</b>	CO <sub>2</sub> : ≤250 ms N <sub>2</sub> O: ≤250 ms Hal, Iso, Sev, Des: ≤300 ms Enf: ≤350 ms O <sub>2</sub> : ≤600 ms
	Gas sample flow rate 200 ml/min, using the adult DRYLINE II watertrap and sampling line (2.5 m):
	CO <sub>2</sub> : ≤250 ms N <sub>2</sub> O: ≤250 ms Hal, Iso, Sev, Des: ≤300 ms Enf: ≤350 ms O <sub>2</sub> : ≤500 ms
<b>Delay time</b>	<4 s
<b>Response time</b>	Measured with a DRYLINE II neonatal watertrap and a 2.5-meter neonatal sampling line: 120 ml/min: CO <sub>2</sub> : ≤4s N <sub>2</sub> O: ≤4.2s O <sub>2</sub> : ≤4s Hal, Iso, Sev, Des, Enf: ≤4.4s
	Measured with a DRYLINE II adult watertrap and a 2.5-meter adult sampling line: 200 ml/min: CO <sub>2</sub> : ≤4.2s N <sub>2</sub> O: ≤4.3s Hal, Iso, Sev, Des, Enf: ≤4.5s O <sub>2</sub> : ≤4s
<b>Anesthetic agent limit</b>	Primary anesthetic agent In full accuracy mode: 0.15%
	Secondary anesthetic agent:

	In full accuracy mode: 5% of primary agent if primary agent is greater than 10%, 0.3% if primary agent is less than or equal to 10%.				
<b>Data sample rate</b>	25 Hz				
Accuracy specifications are affected by the breath rate and I:E change. The end-tidal gas reading is within specification for breath rate below 15 rpm and I:E ratio smaller than 1:1 relative to the gas readings without breath; Add $\pm 6\%$ REL to inaccuracy for Hal and O <sub>2</sub> for breath rate larger than 15 rpm; Add $\pm 6\%$ REL to inaccuracy for all gases for breath rate larger than 30 rpm (inaccuracy for HAL and O <sub>2</sub> are unspecified in this case); inaccuracy is unspecified for breath rate larger than 60 rpm.					
<b>Effect of interference gases on AG measurements</b>					
Gas	Concentration (%)	Quantitative effect(%ABS) <sup>3)</sup>			
		CO <sub>2</sub>	N <sub>2</sub> O	Agent 1)	O <sub>2</sub>
CO <sub>2</sub>	/	/	0.1	0	0.2
N <sub>2</sub> O	/	0.1	/	0.1	0.2
Agent 1) 2)	/	0.1	0.1	0.1	1
Xenon	<100%	0.1	0	0	0.5
Helium	<50%	0.1	0	0	0.5
Ethanol	<0.1%	0	0	0	0.5
Acetone	<1%	0.1	0.1	0	0.5
Methane	<1%	0.1	0.1	0	0.5
Saturated Isopropanol vapour	/	0.1	0	0	0.5
Metered dose inhaler propellants	/	Unspecified	Unspecified	Unspecified	Unspecified
O <sub>2</sub>	/	0.2	0.2	1.0	/
<p>1) Agent represents one of Des, Iso, Enf, Sev, and Hal.</p> <p>2) Multiple agent interference on CO<sub>2</sub>, N<sub>2</sub>O and O<sub>2</sub> is typically the same as single agent interference.</p> <p>3) For CO<sub>2</sub>, N<sub>2</sub>O and Agents, maximum interference from each gas at concentrations within specified accuracy ranges for each gas. The total interference of all gases is never larger than 5%REL.</p>					

**The test method used to determine the RATED respiration rate range and the corresponding effects of end-tidal GAS READING accuracy as a function of respiratory rate as required in 201.7.9.2.9 i) and j)**

The effect of rise time distortion to the gas curve becomes apparent when the breathing rate increases so that the time for a full inspiratory or expiratory event gets shorter.

In those situations, due to the effect of the rise time, the gas curve does not reach the true end-tidal (or first inspired value) and the end-tidal gas value may then be underestimated.

Correspondingly, the first inspired value may be overestimated.

Below is an exaggerated illustration of the effect.

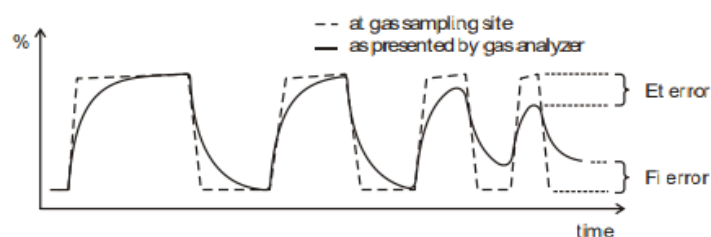

Figure 1 - Gas curve distortion at high breath rates

The breath rate limit for accurately resolved end-tidal gas values (at an I:E ratio of 1:1) may be found in the respective technical specifications of Artema Technology® products.

The effect of other I:E ratios may be calculated by determining the length of the shortest inspiratory/expiratory event that can be resolved accurately:

$$t_{\text{resolved}} = 60 / (2 \times \text{BR}_{\text{limit}}(1:1))$$

$$\text{BR}_{\text{limit}}(I:E) = 60 / ((I + E) \times t_{\text{resolved}})$$

The difference in these results when compared to the rise time's specification is that rise time's only tests 10-90% performance.

This specification is for (0 + accuracy) to (100 -accuracy) % and is thus much tougher.

The ability to properly resolve end-tidal values can be measured by using the set-up described in ISO 80601-2-55:2011 figure 201.101. In short, the method consists of sampling gas from two different sources connected to an electrically controlled pneumatic valve to permit rapid switching between the two sources. During the test, the valve is set to switch gas source at several frequencies (simulating the range of specified breath rates) and for each frequency the end-tidal value presented by the gas analyzer is noted. From a diagram of end-tidal value over frequency, the frequency at which the gas analyzer is no longer able to resolve end-tidal values according to specification is identified.

### The method used to calculate end-tidal GAS READINGS

Inspiratory and end tidal CO<sub>2</sub> concentration readings are identified by AION™ Platinum Multigas Analyzers using the lowest and highest values respectively of the temporal CO<sub>2</sub>-curve. Corresponding readings of N<sub>2</sub>O and anesthetic agents are taken at the same point in time.

Inspiratory and end-tidal O<sub>2</sub> concentration readings are identified by the O<sub>2</sub> mean value during the respiratory phase as identified by the temporal CO<sub>2</sub> curve.

Once correctly identified, the highest and lowest O<sub>2</sub> concentration readings during each part of the phase is presented as inspiratory and end-tidal O<sub>2</sub> respectively.

### Operating Condition

Temperature (°C)		10~40
Relative humidity (noncondensing) (%)		15~95
Barometric (mmHg)		430~790

### Anesthetic Gas(AG) – Dual Gas module Specifications (Option)

CO <sub>2</sub>	
- Range	0 – 76 mmHg; 0 – 10.1 kPa; 0-10% CO <sub>2</sub> STPD (standard temperature and pressure dry)
- Accuracy	± (0.2 vol% + 4% relative)
- Rise Time	- sensor only : 400 ms (average) - with water removal system : 600 ms (average)
- N <sub>2</sub> O Interference	30% N <sub>2</sub> O increases CO <sub>2</sub> reading by 3.25mmHg at 10% CO <sub>2</sub>
Anesthetic Agents	
- Gases	Isoflurane, Desflurane, Sevoflurane
- Range	Iso., Sev.: 0 – 6% Des.: 0 – 18%
- Resolution	0 .01%

- Accuracy	± (0.15% vol% + 4% relative)
- Rise Time	- sensor only : 450 ms (average) - with water removal system : 650 ms (average)
Calibration	Factory calibrated
Power Up Time	30 sec
Delay Time	< 4 sec
Respiration	
- Range	0-150 breaths/min
- Accuracy	±1 breath/min
Flow Rate	
- Range	175 ml/min
- Accuracy	±25ml/min

## 6) Default Parameter Alarm Settings

Alarm	Level	Horse	Dog	Cat, Other
NIBP – S (mmHg)	Medium	80 – 200	80 – 200	80 – 200
NIBP – M (mmHg)	Medium	50 – 170	70 – 140	70 – 170
NIBP – D (mmHg)	Medium	30 – 150	40 – 120	40 – 150
NIBP- PR	Low	60 – 150	60 – 150	90 – 200
SpO <sub>2</sub>	Low	90 – 100	94 – 100	94 – 100
SpO <sub>2</sub> -Rate	Low	60 – 150	60 – 150	90 – 200
Temp1 (°C/°F)	Low	36.0 – 39.4 (98.4 - 102.9)	36.0 – 39.4 (98.4 - 102.9)	36.0- 39.4 (98.4 - 102.9)
PVC Count	Low	0 – 20	0 – 20	0 – 20
ST(mV)	Low	-0.40 – 0.40	-0.40 – 0.40	-0.40 – 0.40
HR	Medium	60 – 150	60 – 150	90 – 200
Temp2 (°C/°F)	Low	36.0 – 39.4 (98.4 - 102.9)	36.0 – 39.4 (98.4 - 102.9)	36.0- 39.4 (98.4 - 102.9)
ΔTemp(°C/°F)	Low	0.0 – 3.4	0.0 – 3.4	0.0 – 3.4

		(0.0-6.1)	(0.0-6.1)	(0.0-6.1)	
RR	Low	10 – 30	10 – 30	10 – 30	
ZeroRR (seconds)	Low	20	40	40	
IBP1,2 (mmHg)	Art-S	Low	80 – 200	60 – 140	40 – 100
	Art-M	Low	40 – 140	40 – 100	30 – 70
	Art-D	Low	20 – 120	30 – 90	20 – 60
	Art-PR	Low	50 – 150	50 – 160	50 – 170
	Fem-S	Low	70 – 150	70 – 150	70 – 150
	Fem-M	Low	50 – 115	50 – 115	50 – 115
	Fem-D	Low	40 – 100	40 – 100	40 – 100
	Fem-PR	Low	50 – 150	50 – 150	50 – 150
	PAP-S	Low	20 – 50	20 – 50	20 – 50
	PAP-M	Low	10 – 40	10 – 40	10 – 40
	PAP-D	Low	5 – 30	5 – 30	5 – 30
	PAP-PR	Low	50 – 150	50 – 150	50 – 150
	RAP-M	Low	3 – 15	3 – 15	3 – 15
	LAP-M	Low	3 – 15	3 – 15	3 – 15
	UAP-S	Low	70 – 150	70 – 150	70 – 150
	UAP-M	Low	50 – 115	50 – 115	50 – 115
	UAP-D	Low	40 – 100	40 – 100	40 – 100
	UAP-PR	Low	50 – 150	50 – 150	50 – 150
	UVP-M	Low	3 – 15	3 – 15	3 – 15
	CVP-M	Low	3 – 15	3 – 15	3 – 15
ICP-M	Low	3 – 15	3 – 15	3 – 15	
User-S	Low	80 – 200	60 – 140	40 – 100	
User -M	Low	40 – 140	40 – 100	30 – 70	
User -D	Low	20 – 120	30 – 90	20 – 60	
User -PR	Low	50 – 150	50 – 160	50 – 170	
EtCO2(mmHg)	Low	25 – 50	25 – 50	25 – 50	
FiCO2(mmHg)	Low	0 – 5	0 – 5	0 – 5	
AwRR	Low	10 – 30	10 – 30	10 – 30	
EtCO2-ZeroRR (seconds)	Low	20	40	40	
IBP3	Low	Same as IBP1,2			
IBP4					
Gas(AG)-EtCO2(mmHg)	Medium	25 – 50	25 – 50	25 – 50	
Gas(AG)-FiCO2(mmHg)	Medium	0 – 5	0 – 5	0 – 5	

Gas(AG)-AwRR	Medium	10 – 30	10 – 30	10 – 30
Gas(AG)-ZeroRR (seconds)	Medium	20	40	40
EtN2O (%)	Medium	0.0 – 13.1	0.0 – 13.1	0.0 – 13.1
FiN2O (%)	Medium	0.0 – 10.8	0.0 – 10.8	0.0 – 10.8
EtO2 (%)	Medium	1.3 – 13.1	1.3 – 13.1	1.3 – 13.1
FiO2 (%)	High	2.4 – 13.1	2.4 – 13.1	2.4 – 13.1
EtDes (%)	Medium	0.0 – 2.6	0.0 – 2.6	0.0 – 2.6
FiDes (%)	Medium	0.0 – 2.6	0.0 – 2.6	0.0 – 2.6
EtEnf (%)	Medium	0.0 – 0.8	0.0 – 0.8	0.0 – 0.8
FiEnf (%)	Medium	0.0 – 0.8	0.0 – 0.8	0.0 – 0.8
EtHal (%)	Medium	0.0 – 0.8	0.0 – 0.8	0.0 – 0.8
FiHal (%)	Medium	0.0 – 0.8	0.0 – 0.8	0.0 – 0.8
EtIso (%)	Medium	0.0 – 0.8	0.0 – 0.8	0.0 – 0.8
FiIso (%)	Medium	0.0 – 0.8	0.0 – 0.8	0.0 – 0.8
EtSev (%)	Medium	0.0 – 0.7	0.0 – 0.7	0.0 – 0.7
FiSev (%)	Medium	0.0 – 0.7	0.0 – 0.7	0.0 – 0.7

## 7) Default Technical Alarm Settings

Biosignal Class	Technical Alarm	Level	Status & Solution
<b>ECG</b>	Module Error	Low	Occurs when communication is not possible due to a module failure, etc. (If the problem persists, contact your service representative.)
	Cable Off	Low	Occurs when no cable is connected. Check the cable connections.
	Lead Fault	Low	Occurs when the lead has fallen. Check lead attachment.
	Saturation	Low	Check lead attachment.
<b>SpO2</b>	Module Error	Low	Occurs when communication is not possible due to a module failure, etc. (If the problem persists, contact your service.)
	Probe Disconnected	Low	Occurs if the cable or probe is not connected. Check the cable connection.

	Probe Off	Low	Occurs when the reusable finger probe is removed from the patient. Check out the probe.
	Poor Signal	Low	Occurs when an interruption in the pulse is detected repeatedly. Check patient and probe location.
	Lost Pulse	Low	SpO2 data is displayed continuously, but the quality of the signal is questionable. Check the patient and probe location.
	Artifact	Low	This indicates when you have trouble breathing. Check to see if these noises are abnormal or irregular.
	Pulse Search	Message	Occurs when an interruption in the pulse is detected repeatedly. Check the patient and probe location.
	Interference	Low	The SpO2 signal has interference. Check for any possible sources of signal noise and check the patient for excessive motion.
	Wrong sensor	Low	Occurs when the wrong sensor is connected.
	Sensor Fault	Low	If the alarm persists, contact your service representative.
<b>Resp</b>	Module Error	Low	Occurs when communication is not possible due to a module failure, etc. (If the problem persists, contact your service.)
	Cable Off	Low	Occurs when no cable is connected. Check the cable connections.
	Lead Fault	Low	Occurs when the lead has fallen. Check lead attachment.
	Saturation	Low	Check lead attachment.
<b>NIBP</b>	Module Error	Low	Occurs when communication is not possible due to a module failure, etc. (If the problem persists, contact your service.)
	Over Pressure	Low	When the cuff pressure is excessive
	Overtime Pressure	Low	Occurs when pressure is applied for more than a specified time.
	NIBP Overrange	Low	The measured NIBP value exceeds the module measurement range. Check the patient's condition.

	NIBP Airway Error	Low	The air tubing may be occluded. Check the air tubing for an occlusion or kinking. If the alarm persists, contact your service representative.
	Weak Signal	Low	The patient's pulse is weak or the cuff is loose. Check the patient's condition and replace the cuff application site.
	Air Leak or Loose Cuff	Low	There is a leak in the cuff or air tubing or pump. Use a cuff of correct type based on the patient size. Apply the cuff and connect the air tubing as instructed in the manual.
	Excessive Motion	Low	Check the patient's condition and reduce patient motion.
	System Fault	Low	If the alarm persists, contact your service representative.
<b>Temp</b>	Module Error	Low	Occurs when communication is not possible due to a module failure, etc. (If the problem persists, contact your service representative.)
	Temp1 Probe Off	Low	Occurs when no cable is connected. Check the cable connections.
	Temp2 Probe Off	Low	
	All Probe Off	Low	
<b>IBP</b>	Module Error	Low	Occurs when communication is not possible due to a module failure, etc. (If the problem persists, contact your service representative.)
	Cable Off	Low	Occurs when no cable is connected. Check the cable connections.
	Pulse Search	Message	Finding pulses.
<b>EtCO2</b>	Module Off	Low	Check the module connections. Disconnect and reconnect the module cable
	Sensor Over Temp	Low	Ambient temperature is too high or there is a module failure. 1. Lower the operating temperature. 2. Reinsert the module. 3. If the alarm continues, the CO2 module may have failed, contact your service representative.
	Sensor Faulty	Low	Check that the sensor is properly plugged in. Reinsert or reset the sensor if necessary. If error persists, return sensor to factory for servicing.

	Check Sampling Line	Low	Check that the sampling line is not occluded or kinked.
	Zero Required	Low	Check airway adapter and clean if necessary. If this does not correct the error, perform an adapter zeroing. If you have to do adapter zeroing more than once, there can exist an error in the hardware.
	CO2 out of range	Low	If alarm persists, perform a zero calibration.
	Check Adapter	Low	It usually occurs when the airway adapter is removed from the module or when there is an optical blockage on the windows of the airway adapter. It may also be caused by failure to perform zeroing when the adapter type is changed. To clear, clean airway adapter if mucus or moisture is visible. If the adapter is clean, perform zeroing.
	Sample line disconnected	Low	Check that the sampling line is not occluded or kinked.
<b>Anesthetic Gas (AG)</b>	Module Off	Low	Check the module connections. Disconnect and reconnect the module cable
	No Watertrap	Low	Check the connections of the watertrap and re-connect it.
	Change Watertrap	Low	Replace the watertrap.
	Watertrap Type Mismatch	Low	Check the patient category and use a correct watertrap.
	Zero Failed	Low	There is external electromagnetic interference, airway occlusion or module failure. 1. Check for external inference sources. 2. Check for "Airway Occluded" alarm message. Remove the occlusion. 3. If the alarm persists, contact your service representative.
	Calibration Error	Low	When the alarm persists, contact your service representative.
	Airway Occluded	Low	1. Check if the sample line is occluded. 2. Replace the sample line.

			3. Reinsert the module. If the alarm persists, contact your service representative.
	Unspecified accuracy	Low	Displayed when the input data is out of accuracy range.
	Data limit error	Low	Displayed when the input data is out of the measurement range.
	HW error	Low	When the alarm persists, contact your service representative.
	SW error	Low	When the alarm persists, contact your service representative.
	Pump error	Low	When the alarm persists, contact your service representative.
	Temp/Press Error	Low	When the alarm persists, contact your service representative.
	IR signal Error	Low	When the alarm persists, contact your service representative.
	Motor speed Error	Low	When the alarm persists, contact your service representative.
	O2 Error	Low	When the alarm persists, contact your service representative.
<b>System</b>	Low Battery	Low	The battery is very low. Immediately connect the monitor to the AC adapter.

## 8) Default Display Settings

Item	Default Setting
Primary ECG	II
Arrhythmia	Lethal
Print waveform1	Lead II
Print waveform2	SpO2
Print waveform3	Resp
Alarm print	Off
NIBP interval	Off
NIBP cuff size	Large
RR(Resp) lead	II
Alarm volume	50%

---

QRS volume	Off
Pulse volume	Off
Units for height	Inch
Units for weight	Lbs
Temperature units	°F
Blood pressure units	mmHg
EtCO2 units	mmHg
AG units	%
NIBP limit type	Systolic
ECG filter	Monitor
PVCs	ON
ST	OFF

---

## PART 21. Abbreviations and Symbols

Abbreviations and symbols are alphabetized by reference, which can be read while reading the manual or using the veterinary multiparameter monitor.

### 1) Abbreviations

A	amps
AC	alternating current
AG	Anesthetic Gas
ARRYTHM	arrhythmia
ASYS	asystole
Auto, AUTO	automatic
AUX	Auxiliary
aVF	left foot augmented lead
aVL	left arm augmented lead
aVR	right arm augmented lead

#### **B**

BPM	beats per minute
-----	------------------

#### **C**

C	Celsius
CAL	calibration
cm, CM	centimeter

#### **D**

D	diastolic
DC	direct current
DEFIB, Defib	defibrillator
DIA	diastolic

#### **E**

ECG	electrocardiograph
EMC	electromagnetic compatibility
EMI	electromagnetic interference

---

ESU           electrosurgical cautery unit

**F**

F             Fahrenheit

**G**

g             gram

**H**

HR           heart rate, hour

Hz           hertz

**I**

ICU          intensive care unit

Inc          incorporated

**K**

Kg, KG       kilogram

KPa          kilopascal

**L**

L             liter, left

LA           left arm, left atrial

LBS          pounds

LCD          liquid crystal display

LED          light emitting diode

LL           left leg

**M**

M mean,      minute

m             meter

MIN,         minute

MM, mm      millimeters

MM/S         millimeters per second

MMHG, mmHg millimeters of mercury

mV           millivolt

**N**

---

NIBP	non-invasive blood pressure
<b>O</b>	
OR	operating room
<b>P</b>	
PVC	premature ventricular complex
<b>Q</b>	
QRS	interval of ventricular depolarization
<b>R</b>	
RA	right arm, right atrial
RESP	respiration
RL	right leg
RR	respiration rate
<b>S</b>	
S	systolic
sec	second
SpO2	arterial oxygen saturation from pulse oximetry
SYNC, Sync	synchronization
SYS	systolic
<b>T</b>	
Temp, TEMP	temperature
<b>U</b>	
<b>V</b>	
V	precordial lead
V	volt
V-Fib, VFIB	ventricular fibrillation
VTAC	ventricular tachycardia

**W****X**

X multiplier when used with a number (2X)

Y

Z

## 2) Symbols

&	and
°	degree(s)
>	greater than
<	less than
–	minus
#	number
%	percent
±	plus or minus

**Caution**

Please read this operation manual before operating the veterinary multiparameter monitor. Keep it well for future reference.

**Brio X3VET /Brio X5VET /Brio X7VET User Manual**

**Copyright © 2023 Bionet Co.,Ltd. All Rights Reserved.**



Copyright Ownership.

No part of this manual may be reproduced, stored, or introduced into a retrieval system. Nor can it be transmitted, in any form, by any means, without the prior written consent of the copyright owner Bionet.

The entire manual should be carefully read.

This manual contains information on limitations, cautions, and warnings associated with the use of the Brio veterinary multiparameter monitors.

Regardless of the complexity of the equipment, veterinary multiparameter monitoring device should never be used to replace human care, attention, and judgement by trained health professionals.

**CAPNOSTAT, LoFlo®** is trademark of Respironics.

All other brand or product names are the property of their respective owners.

# PRODUCT WARRANTY

<b>Product Name</b>	<b>Patient Monitor</b>
<b>Model Name</b>	<b>Brio X3VET / Brio X5VET /Brio X7VET</b>
<b>Approval Number</b>	
<b>Approval Date</b>	
<b>Serial Number</b>	
<b>Warranty Period</b>	<b>1 year from date of purchase</b>
<b>Date of Purchase</b>	
<b>Customer section</b>	<b>Hospital Name:</b> <b>Address:</b> <b>Name:</b> <b>Phone:</b>
<b>Sales Agency</b>	
<b>Manufacturer</b>	

- ※ Thank you for purchasing Veterinary multiparameter monitor Siri.
- ※ This monitor is a medical device.
- ※ The monitor is manufactured and passed through strict quality control and through inspection.
- ※ Compensation standard concerning repair, replacement, refund of the product complies with "Consumer's Protection Law" noticed by Korea Fair Trade Commission.



## **Bionet Co., Ltd.**

Model Name: Brio X3VET / Brio X5VET /Brio X7VET